



Distributed in North America by



P R E M I U M

KNURLING
TOOLS

MARKING
TOOLS

CATALOGUE 2022





As a global leader in knurling technology Hommel+Keller manufactures products of superior quality based on decades of experience, always with the incentive of continuous improvement. Our premium brand, which can look back on a long and proud history, is custom tailored to the requirements of our customers.



Hommel+Keller
Film new building 2020

QUICK

AT THE FOREFRONT!

Tools used in knurling and marking technology always have special requirements with respect to quality, precision, stability and especially technological know-how. QUICK is the high-end brand of Hommel+Keller Präzisionswerkzeuge GmbH for exceptionally precise knurling and marking tools. Because here, design is combined with functionality and innovation with experience.

FORMING AND CUTTING: The QUICK product spectrum offers innovative solutions for diverse knurling technology applications. For both form knurling and cut knurling tools, QUICK fulfils the most stringent quality standards and masters even difficult tasks with ease.

MARKING TOOLS: New to the program are the QUICK marking tools, which make it possible to mark workpieces with a wide variety of geometries in a matter of seconds. Through single marking segments the marking text can be individually adapted.

TOOLS IN ACTION: QUICK is used wherever absolute precision and first-rate surface quality are needed. In the automotive sector, for example, in mechanical engineering, in the manufacture of timepieces and in many other industries. Our selection of knurling profiles will impress you – and your customers, too.

CONVINCING QUALITY Precision and premium quality – that is our passion and what motivates us to deliver maximum performance every day. And simultaneously a promise to our customers. Because you are good only if we are. We think ahead, to continuously develop customer-oriented innovations and to find new solutions. Our goal: joint success.

ANYWHERE IN THE WORLD: Take advantage of our services: A global sales network and customer proximity, excellent on-site technical support, as well as fast spare parts availability and tool maintenance.

COMMUNITY: What makes us special: We not only have excellent technological competence, but also know the needs of our customers very well. For you, that means: Whether in production or processing – at Hommel+Keller you will receive professional service at all times. And you will always find your personal contact person, who will respond to your concerns in a flexible and customer-oriented manner.

CONTENTS

QUICK KNURLING TOOLS

Product finder 4

Cut knurling tools

Overview of cut knurling tools	6
C601	8
C602	10
C611 / 612	12
SET C610	13
C621 / C622	14
Application example cut knurling	15

Form knurling tools

Overview of form knurling tools	16
F701	18
F711	19
F712	20
F751	21
F761	22
Application examples form knurling	23

Cut and form knurling tools

C693 / F791 / F792	24
--------------------	----

Knurling wheels

Knurling wheels for cut knurling	26
Knurling wheels for form knurling	29

QUICK MARKING TOOLS

Marking tool QBW 432	32
Application example marking	33
Marking segments N° 43	34

TECHNOLOGY

Optimization knurling process	35
DIN standards for profiles and pitches	35
Process characteristics	36
Influencing factors	37
Reference values for cutting speed and feed rate	38
Material displacement in form knurling	39

QUICK PRODUCT FINDER

In knurling technology there are two different processes: **cut knurling** and **form knurling**. Both processes have their special applications and areas of utilisation (info p. 36).

Application recommendation cut knurling

C602:
Perfect for challenging visual knurling

C693:
Perfect force distribution for small workpiece

Application recommendation form knurling:

F701 / F11:
High process stability
User-friendly handling



F712 / F792:
Knurling up to a shoulder

F761:
High process stability for long workpieces

F791 / F792:
Perfect force distribution for small workpiece

Application recommendation form and cut knurling

F791 / F792 / C693:
Perfect force distribution for small workpiece

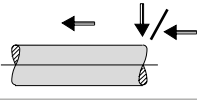
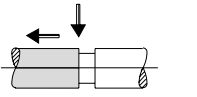
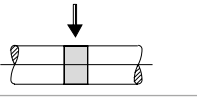
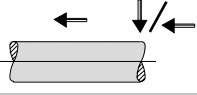
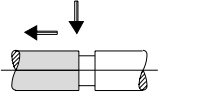
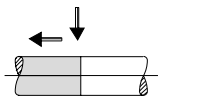
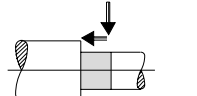
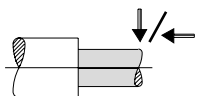
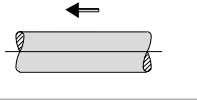
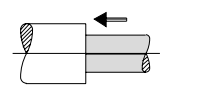
Profile on workpiece (DIN 82)		RAA	RBL / RBR	RGE
				
Cut knurling		Tool selection for cut knurling		
	Knurling starting at workpiece beginning	C601 / C611 / C621		C602 / C612 / C622 / C693
	Knurling starting in centre of workpiece / after plunge cut			C602 / C612 / C622
Form knurling		Tool selection for form knurling		
	Knurling on workpiece centre / without plunge cut	F701 / F711 / F712 / F751 / F761	F711 / F712 / F751 / F761	
	Knurling starting at workpiece beginning	F701 / F711 / F712 / F751 / F761 / F791	F711 / F712 / F751 / F761 / F791	
	Knurling starting in centre of workpiece / after plunge cut	F701 / F711 / F712 / F751 / F761	F711 / F712 / F751 / F761	
	Knurling starting on workpiece centre / without plunge cut	F701 / F711 / F712 / F751 / F761	F711 / F712 / F751 / F761	
	Knurling up to a shoulder	F712	F712	
	Knurling starting at workpiece beginning up to a shoulder	F712 / F792	F712 / F792	
Form and cut knurling		One tool for form and cut knurling with interchangeable jaws.		
	Knurling starting at workpiece beginning	F791 / F792	F791 / F792 / C693	
	Knurling starting at workpiece beginning up to a shoulder	F792	F792	

CUT KNURLING

Possible knurling profiles on the workpiece:

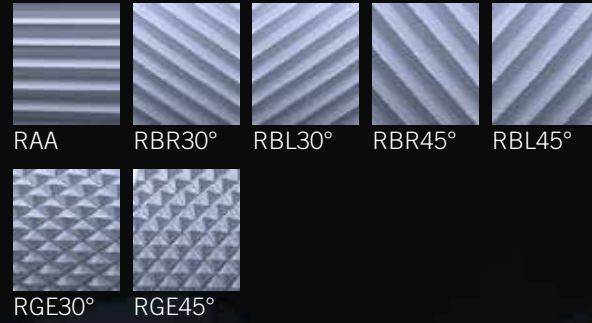

CUT KNURLING

Cut knurling is a machining process that uses cutting. The material is removed while being supplied at an axial feed rate. This process can therefore also be used for thin-walled or soft materials, as well as hard-to-machine materials.







ADDED VALUES

- maximum precision and surface quality, therefore especially suitable for visible knurling
- knurling of thin-walled workpieces is possible without deformation
- time savings due to faster cutting speed and feed rate
- machining of virtually all materials, including grey cast iron and plastic
- zero or only minimal alteration of the workpiece diameter
- minimal surface compaction



OVERVIEW OF CUT KNURLING TOOLS

With the product finder for cut knurling tools you can find your desired QUICK product faster. You receive all relevant tool data, as well as possible profiles, the corresponding knurling wheels and the possible direction of machining at a glance.

Tool series	Workpiece Ø [mm]	Profile on workpiece	Profile on knurling wheel		Shank [mm]	Knurling wheel Ø [mm]	Knurling	Knurling profiles			
								RAA	RBL	RBR	RGE
 C601 PAGE 8	1,5 – 12	RAA RBR30° RBL30° RBR45° RBL45°	right-hand use: 1 x BR30°	left-hand use: 1 x BL30°	8 / 10 / 12 / 16	8.9	starting at the workpiece	●	●	●	–
	3 – 50		1 x AA	—	8 / 10 / 12 / 16	14.5	starting after plunge cut	●	●	●	–
	5 – 250		1 x BL15°	—	1 x BR15°	20 / 25	21.5				
 C602 PAGE 10	1.5 – 12	RGE30° RGE45°	2 x AA		10 / 12 / 16	8.9	starting at the workpiece	–	–	–	●
	3 – 50		1 x BR15° / 1 x BL15°		10 / 12 / 16	14.5	starting after plunge cut	–	–	–	●
	5 – 250				16 / 20 / 25	21.5					
 C611 PAGE 12	3 – 50	RAA RBR30° RBL30° RBR45° RBL45°	right-hand use: 1 x BR30°	left-hand use: 1 x BL30°	10 / 12 / 16	14.5	starting at the workpiece	●	●	●	–
	5 – 250		1 x AA	—	20 / 25	21.5	starting after plunge cut	●	●	●	–
 C612 PAGE 12	3 – 50	RGE30° RGE45°	2 x AA		10 / 12 / 16	14.5	starting at the workpiece	–	–	–	●
	5 – 250		1 x BR15° / 1 x BL15°		20 / 25	21.5	starting after plunge cut	–	–	–	●
 C621 PAGE 14	20 – 3000	RAA RBR30° RBR45°	1 x BR30° 1 x AA 1 x BL15°		27	42	starting at the workpiece starting after plunge cut	● ●	● ●	● ●	– –
 C622 PAGE 14	20 – 1000	RGE30° RGE45°	2 x AA		40	32	starting at the workpiece	–	–	–	●
	30 – 3000		1 x BR15° / 1 x BL15°		57	42	starting after plunge cut	–	–	–	●

CUT KNURLING TOOL C601

DISCONTINUED MODEL

AVAILABLE UNTIL 2022-06-30



KNURLING PROFILE ON WORKPIECE (DIN 82):

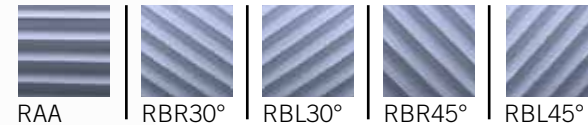

SELECTION OF KNURLING WHEELS (DIN 403):

RIGHT-HAND USE	BR30°	AA	—	BL15°	—
LEFT-HAND USE	BL30°	—	AA	—	BR15°

PRODUCT FEATURES

- developed for minimal installation space and maximum stability
- designed for smallest workpiece diameters
- user-friendly handling

Item no. (right-hand version)	Item no. (left-hand version)	Model	Workpiece Ø [mm]	Knurling wheel (Ø x w x b) [mm]	Dimensions [mm]							
					a	b	c	d	e	f	x	
32000012 <input checked="" type="checkbox"/>	32000011	C601-10	1.5 – 12	8.9 x 2.5 x 4	10	10	108	23.5	20	20.3	0.8	
32000014 <input checked="" type="checkbox"/>	32000013	C601-12	1.5 – 12	8.9 x 2.5 x 4	12	12	108	23.5	20	22	0.8	

Available from factory stock

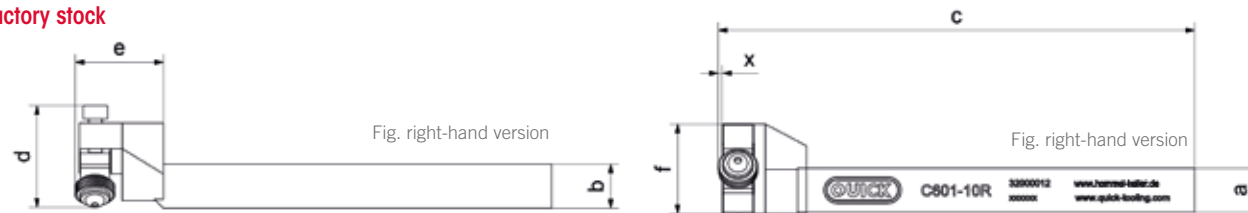

NEW CUT KNURLING TOOL C601



KNURLING PROFILE ON WORKPIECE (DIN 82):

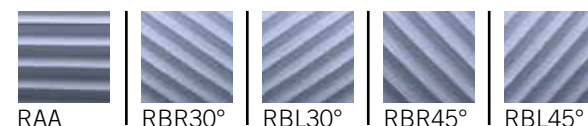

SELECTION OF KNURLING WHEELS (DIN 403):

RIGHT-HAND USE	BR30°	AA	—	BL15°	—
LEFT-HAND USE	BL30°	—	AA	—	BR15°

PRODUCT FEATURES

- optimized for Swiss type lathe applications
- knurl carrier are flush with outer edge of shank
- smaller design - reduced height of the tool head
- optimized tool positioning: upper edge of shank = center height
- improved stability through optimization of the interfaces
- designed for smallest workpiece diameters
- user-friendly handling

Item no. (right-hand version)	Item no. (left-hand version)	Model	Workpiece Ø [mm]	Knurling wheel (Ø x w x b) [mm]	Dimensions [mm]							
					a	b	c	d	e	f	x	
32000357 <input checked="" type="checkbox"/>	32000356	C601-08	1.5 – 12	8.9 x 2.5 x 4	8	10	115	25	20	18	0.9	
32000319 <input checked="" type="checkbox"/>	32000318	C601-10	1.5 – 12	8.9 x 2.5 x 4	10	10	115	25	20	18	0.9	
32000291 <input checked="" type="checkbox"/>	32000292	C601-12	1.5 – 12	8.9 x 2.5 x 4	12	12	115	25	20	20	0.9	
32000293 <input checked="" type="checkbox"/>	32000294	C601-16	1.5 – 12	8.9 x 2.5 x 4	16	12	115	25	20	24	0.9	
32000358 <input checked="" type="checkbox"/>	32000359	C601-08	3 – 50	14.5 x 3 x 5	8	10	120	25	25	18	1.75	
32000289 <input checked="" type="checkbox"/>	32000288	C601-10	3 – 50	14.5 x 3 x 5	10	10	120	25	25	18	1.75	
32000028 <input checked="" type="checkbox"/>	32000243	C601-12	3 – 50	14.5 x 3 x 5	12	12	120	25	25	20	1.75	
32000023 <input checked="" type="checkbox"/>	32000022	C601-16	3 – 50	14.5 x 3 x 5	16	12	120	25	25	24	1.75	

Available from factory stock

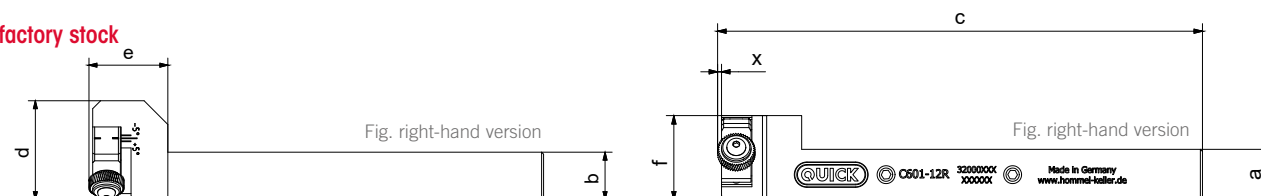

NEW

CUT KNURLING TOOL C601



KNURLING PROFILE ON WORKPIECE (DIN 82):

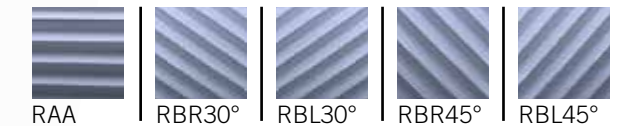

SELECTION OF KNURLING WHEELS (DIN 403):

RIGHT-HAND USE	BR30°	AA	—	BL15°	—
LEFT-HAND USE	BL30°	—	AA	—	BR15°

PRODUCT FEATURES

- developed for minimal installation space and maximum stability
- designed for smallest workpiece diameters
- user-friendly handling

Item no. (right-hand version)	Item no. (left-hand version)	Model	Workpiece Ø [mm]	Knurling wheel (Ø x w x b) [mm]	Dimensions [mm]							
					a	b	c	d	e	f	x	
32000032 <input checked="" type="checkbox"/>	32000093	C601-20	5 - 250	21.5 x 5 x 8	20	20	125	43,2	36,8	30	1.75	
32000165 <input checked="" type="checkbox"/>	32000242	C601-25	5 - 250	21.5 x 5 x 8	25	25	125	43,2	36,8	30	1.75	

Available from factory stock

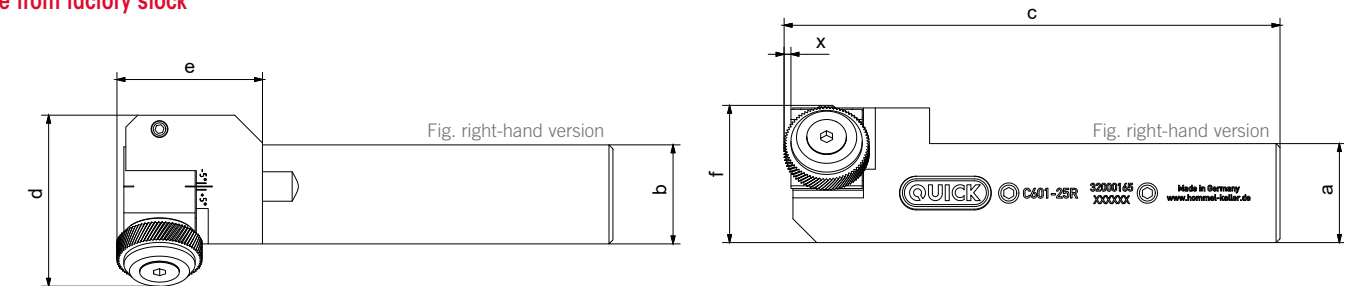

SPARE PARTS C601

E-KIT C601 - NEW

Item no.	Knurling wheel (Ø x w x b) [mm]
22BHR0506	8.9 x 2.5 x 4
22BHR0507	14.5 x 3 x 5
22BHR0508	21.5 x 5 x 8



CUT KNURLING TOOL C602

DISCONTINUED MODEL

AVAILABLE UNTIL 2022-06-30



KNURLING PROFILE ON WORKPIECE (DIN 82):

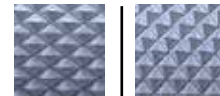

RGE30° RGE45°

SELECTION OF KNURLING WHEELS (DIN 403):

2x AA | 1x BL15°
1x BR15°

PRODUCT FEATURES

- developed for minimal installation space and maximum stability
- designed for smallest workpiece diameters
- easy fine adjustment of the knurl carrier

Order no. (right-hand version)	Order no. (left-hand version)	Model	Workpiece Ø [mm]	Knurling wheel (Ø x w x b) [mm]	Dimensions [mm]					
					a	b	c	d	e	f
32000006 <input checked="" type="checkbox"/>	32000005	C602-10	1,5 – 12	8.9 x 2.5 x 4	10	10	106	29.7	29.4	24.3
32000008 <input checked="" type="checkbox"/>	32000007	C602-12	1,5 – 12	8.9 x 2.5 x 4	12	12	106	29.7	29.4	24.3

Available from factory stock

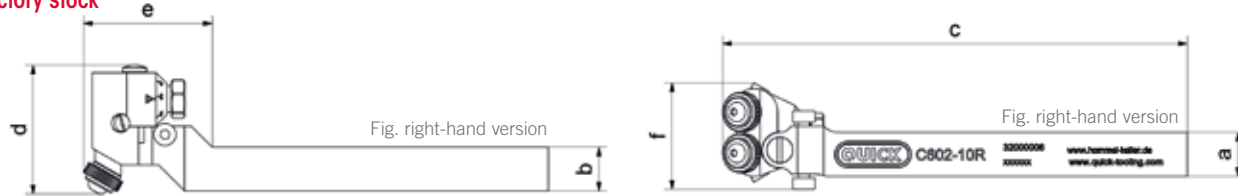

NEW

CUT KNURLING TOOL C602



KNURLING PROFILE ON WORKPIECE (DIN 82):



RGE30° RGE45°

SELECTION OF KNURLING WHEELS (DIN 403):

2x AA | 1x BL15°
1x BR15°

PRODUCT FEATURES

- optimized for Swiss type lathe applications
- knurl carrier are flush with outer edge of shank
- optimized tool positioning: upper edge of shank = center height
- easy fine adjustment of the knurl carrier
- designed for smallest workpiece diameters
- user-friendly handling

Order no. (right-hand version)	Order no. (left-hand version)	Model	Workpiece Ø [mm]	Knurling wheel (Ø x w x b) [mm]	Dimensions [mm]					
					a	b	c	d	e	f
32000363 <input checked="" type="checkbox"/>	32000364	C602-10	1.5 – 12	8.9 x 2.5 x 4	10	10	100	30	20.2	22.7
32000365 <input checked="" type="checkbox"/>	32000366	C602-12	1.5 – 12	8.9 x 2.5 x 4	12	12	100	30	20.2	23.3
32000244 <input checked="" type="checkbox"/>	32000245	C602-16	1.5 – 12	8.9 x 2.5 x 4	16	12	100	30	20.2	27
32000269 <input checked="" type="checkbox"/>	32000270	C602-10	3 – 50	14.5 x 3 x 5	10	10	107	31.5	27	29.5
32000025 <input checked="" type="checkbox"/>	32000024	C602-12	3 – 50	14.5 x 3 x 5	12	12	107	31.5	27	29.5
32000252 <input checked="" type="checkbox"/>	32000253	C602-16	3 – 50	14.5 x 3 x 5	16	12	107	31.5	27	30.7

Available from factory stock

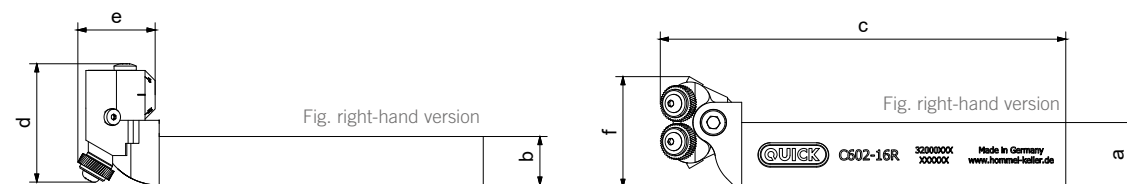

NEW

CUT KNURLING TOOL C602



KNURLING PROFILE ON WORKPIECE (DIN 82):

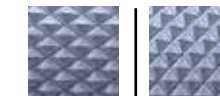

RGE30° RGE45°

SELECTION OF KNURLING WHEELS (DIN 403):

2x AA | 1x BL15°
1x BR15°

PRODUCT FEATURES

- developed for minimal installation space and maximum stability
- designed for smallest workpiece diameters
- easy fine adjustment of the knurl carrier

Item no. (right-hand version)	Item no. (left-hand version)	Model	Workpiece Ø [mm]	Knurling wheel (Ø x w x b) [mm]	Dimensions [mm]					
					a	b	c	d	e	f
32000282 <input checked="" type="checkbox"/>	32000281	C602-16	5 - 250	21.5 x 5 x 8	16	20	143	69.4	56	50
32000021 <input checked="" type="checkbox"/>	32000086	C602-20	5 - 250	21.5 x 5 x 8	20	20	143	69.4	56	50
32000065 <input checked="" type="checkbox"/>	32000087	C602-25	5 - 250	21.5 x 5 x 8	25	25	143	69.4	56	50

Available from factory stock

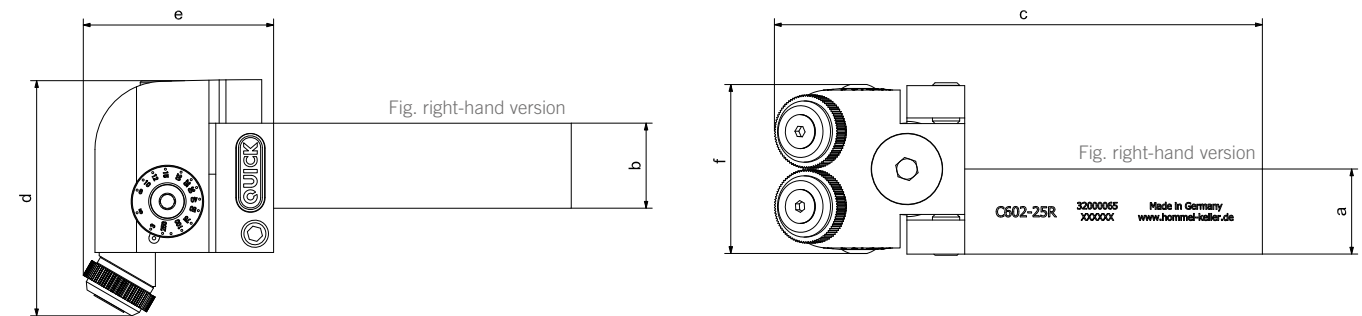

SPARE PARTS C602

E-KIT C602

Item no.	Knurling wheel (Ø x w x b) [mm]
22BHR0506	8.9 x 2.5 x 4
22BHR0507	14.5 x 3 x 5
22BHR0508	21.5 x 5 x 8



SHANK ASSEMBLED C602 - NEW

Item no. (right-hand version)	Item no. (left-hand version)	Description
22BHR0709	22BHR0710	shank 10 x 10
22BHR0706	22BHR0705	shank 12 x 12
22BHR0658	22BHR0660	shank 16 x 12
22BHR0743	22BHR0742	shank 16 x 20
22BHR0330	22BHR0329	shank 20 x 20
22BHR0342	22BHR0341	shank 25 x 25

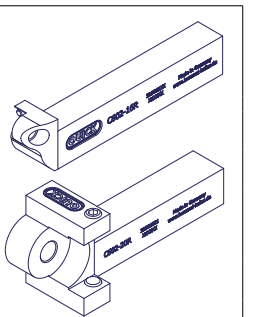

HEAD ASSEMBLED C602 - NEW

Item no. (for knurl holder Ø 8,9)	Item no. (for knurl holder Ø 14,5)	Item no. (for knurl holder Ø 21,5)	Description
22BHR0662	22BHR0237	—	shank 10 x 10
22BHR0662	22BHR0237	—	shank 12 x 12
22BHR0662	22BHR0237	—	shank 16 x 16
—	—	22BHR0620	shank 16 x 20
—	—	22BHR0620	shank 20 x 20
—	—	22BHR0620	shank 25 x 25



CUT KNURLING TOOL C611



KNURLING PROFILE ON WORKPIECE (DIN 82):

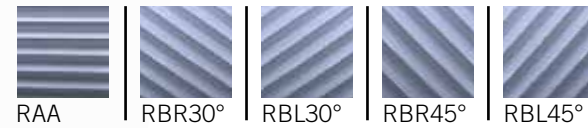

SELECTION OF KNURLING WHEELS (DIN 403):

RIGHT-HAND USE	BR30°	AA	—	BL15°	—
LEFT-HAND USE	BL30°	—	AA	—	BR15°

PRODUCT FEATURES

- adaptable, patented QUICK coolant nozzle
- multifunctional: for use in front of and behind the rotation centre
- flexible shank variation
- head and shank fully exchangeable due to compatible interface
- quick and easy adjustment of the working area with the enclosed setting gauge

Item no.	Model	Workpiece Ø [mm]	Knurling wheel (Ø x w x b) [mm]	Dimensions [mm]							
				a	b	c	d	e	f	x	
32000037	C611-10M	3 – 50	14.5 x 3 x 5	10	16	106	35	25.6	32	1.8	
32000038	C611-12M	3 – 50	14.5 x 3 x 5	12	16	106	35	25.6	32	1.8	
32000039	C611-16M	3 – 50	14.5 x 3 x 5	16	16	106	35	25.6	32	1.8	
32000043	C611-20M	5 – 250	21.5 x 5 x 8	20	25	149	56.5	38.3	50	1.7	
32000044	C611-25M	5 – 250	21.5 x 5 x 8	25	25	149	56.5	38.3	50	1.7	

✓ Available from factory stock

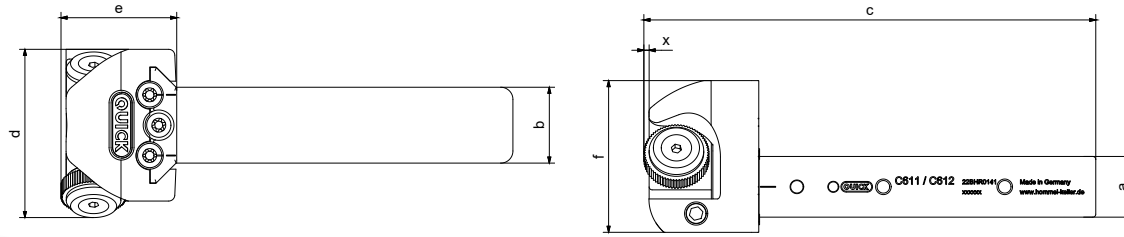

CUT KNURLING TOOL C612



KNURLING PROFILE ON WORKPIECE (DIN 82):

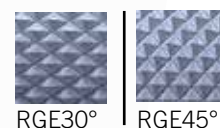

SELECTION OF KNURLING WHEELS (DIN 403):

2x AA	1x BL15°
	1x BR15°

PRODUCT FEATURES

- adaptable, patented QUICK coolant nozzle
- multifunctional: for use in front of and behind the rotation centre
- flexible shank variation
- head and shank fully exchangeable due to compatible interface
- synchronised knurl holder for adjusting the working range
- quick and easy adjustment of the working area with the enclosed setting gauge

Item no.	Model	Workpiece Ø [mm]	Knurling wheel (Ø x w x b) [mm]	Dimensions [mm]					
				a	b	c	d	e	f
32000034	C612-10M	3 – 50	14.5 x 3 x 5	10	16	115	36	34.7	35.8
32000035	C612-12M	3 – 50	14.5 x 3 x 5	12	16	115	36	34.7	35.8
32000036	C612-16M	3 – 50	14.5 x 3 x 5	16	16	115	36	34.7	35.8
32000041	C612-20M	5 – 250	21.5 x 5 x 8	20	25	158	64.4	47.7	50
32000042	C612-25M	5 – 250	21.5 x 5 x 8	25	25	158	64.4	47.7	50

✓ Available from factory stock

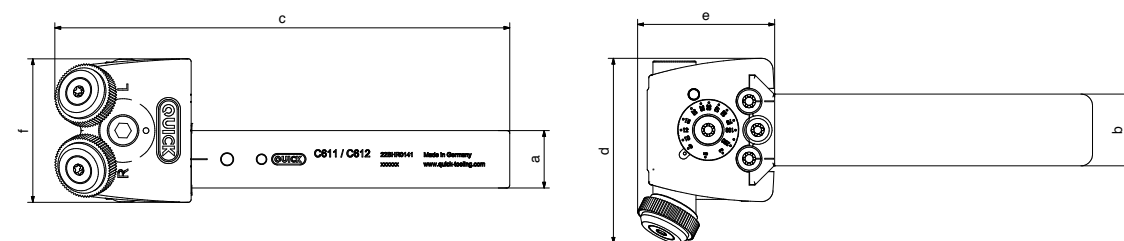

CUT KNURLING TOOL SET C610



SET consisting of:

- C611-12 (with shank 12 mm x 16 mm)
- C612-16 (with shank 16 mm x 16 mm)
- 1 x shank 10 mm x 16 mm
- coolant nozzle (22BHR0145)

Item no.	Model	Shank [mm]	Workpiece Ø [mm]	Knurling wheel (Ø x w x b) [mm]
32000040	C611	10 / 12 / 16	3 – 50	14.5 x 3 x 5
	C612			14.5 x 3 x 5

SET consisting of:

- C611-20 (with shank 20 mm x 25 mm)
- C612-25 (with shank 25 mm x 25 mm)
- coolant nozzle (22BHR0136)

Item no.	Model	Shank [mm]	Workpiece Ø [mm]	Knurling wheel (Ø x w x b) [mm]
32000045	C611	20 / 25	5 – 250	21.5 x 5 x 8
	C612			21.5 x 5 x 8

SPARE PARTS C611 / C612

E-KIT C611 / C612

Item no.	Knurling wheel (Ø x w x b) [mm]
22BHR0507	14.5 x 3 x 5
22BHR0508	21.5 x 5 x 8



COOLANT NOZZLE C611 / C612

Item no.	Knurling wheel (Ø x w x b) [mm]
22BHR0145	14.5 x 3 x 5
22BHR0136	21.5 x 5 x 8



The adjustable coolant nozzle ensures the precise supply of coolant to the workpiece and the knurling wheels.

ADAPTER FOR SWISS TYPE LATHE APPLICATIONS

Adapter C611 Item no.	Adapter C612 Item no.	Description
22BHR0149	22BHR0152	Adapter 10 x 10
22BHR0148	22BHR0151	Adapter 12 x 12
22BHR0147	22BHR0150	Adapter 16 x 16



SHANK ASSEMBLED C611 / C612

Item no.	Description
22BHR0131	Shank 10 x 16
22BHR0132	Shank 12 x 16
22BHR0133	Shank 16 x 16
22BHR0139	Shank 20 x 25
22BHR0142	Shank 25 x 25

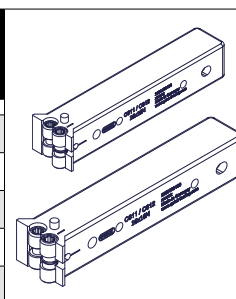

HEAD ASSEMBLED

Head C611 Item no.	Head C612 Item no.	Description
22BHR0130	22BHR0129	Shank 10 x 16
22BHR0130	22BHR0129	Shank 12 x 16
22BHR0130	22BHR0129	Shank 16 x 16
22BHR0140	22BHR0141	Shank 20 x 25
22BHR0140	22BHR0141	Shank 25 x 25



CUT KNURLING TOOL C621



KNURLING PROFILE ON WORKPIECE (DIN 82):

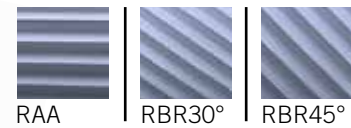

SELECTION OF KNURLING WHEELS (DIN 403):

BR30° | AA | BL15°

PRODUCT FEATURES

- designed for the largest possible workpiece diameter
- ideal for heavy-duty and roll turning lathe etc.
- maximum stability due to solid construction

Item no.	Model	Workpiece Ø [mm]	Knurling wheel (Ø x w x b) [mm]	Dimensions [mm]					
				a	b	c	d	e	f
32000018 <input checked="" type="checkbox"/>	C621-27R	20 – 3000	42 x 12 x 18	27	35	194	70.5	89	57.2

Available from factory stock

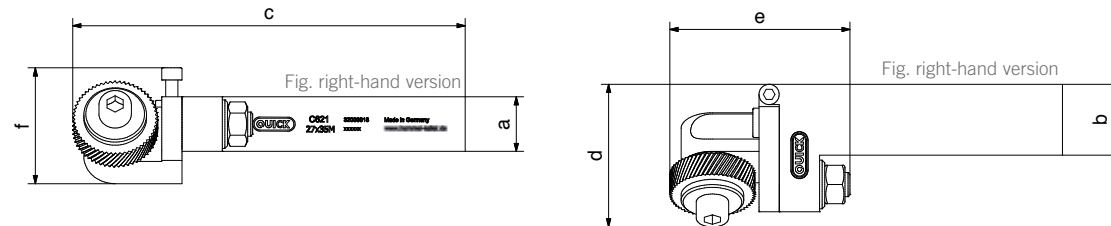

CUT KNURLING TOOL C622



KNURLING PROFILE ON WORKPIECE (DIN 82):

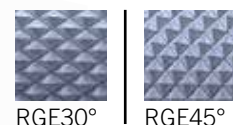

SELECTION OF KNURLING WHEELS (DIN 403):

2x AA | 1x BL15°
1x BR15°

PRODUCT FEATURES

- designed for the largest possible workpiece diameter
- ideal for heavy-duty and roll turning lathe etc.
- maximum stability due to solid construction
- synchronised knurl carrier for adjusting the working range

Item no.	Model	Workpiece Ø [mm]	Knurling wheel (Ø x w x b) [mm]	Dimensions [mm]					
				a	b	c	d	e	f
32000015 <input checked="" type="checkbox"/>	C622-40	20 - 1000	32 x 8 x 14	40	45	275.5	109	115.5	79
32000016 <input checked="" type="checkbox"/>	C622-57	30 - 3000	42 x 12 x 18	57	85	438.5	161.5	169.5	118

Available from factory stock

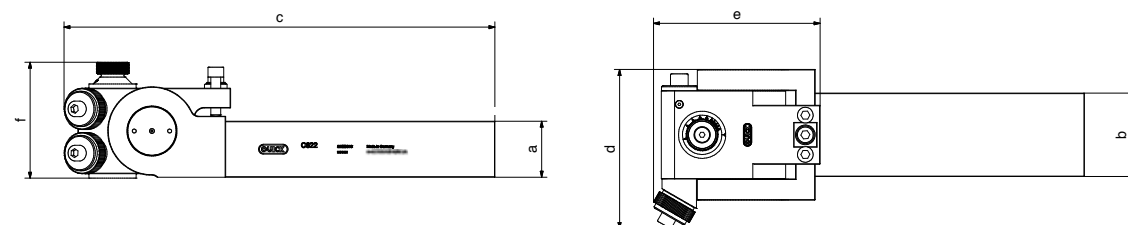

SPARE PARTS C621 / C622

E-KIT C621 / C622

E-KIT 621 Item no.	E-KIT 622 Item no.	Knurling wheel (Ø x w x b) [mm]
—	22BHR0509	32 x 8 x 14
22BHR0510	22BHR0511	42 x 12 x 18



APPLICATION EXAMPLE CUT KNURLING

C602 VISUAL KNURLING FOR HIGHEST DEMANDS IN DESIGN, OPTICS AND FUNCTIONALITY

PICTURED PROFILE: RGE30° WITH FLATTENED TIPS FOR THE PERFECT HAPTIC



WORKING AREA: 5-250 mm
KNURLING WHEEL: 2 x AA | 21.5 x 5 x 8

WORKING AREA: 3-50 mm
KNURLING WHEEL: 2 x AA | 14.5 x 3 x 5

WORKING AREA: 1.5-12 mm
KNURLING WHEEL: 2 x AA | 8.9 x 2.5 x 4

FORM KNURLING

Possible knurling profiles on the workpiece:

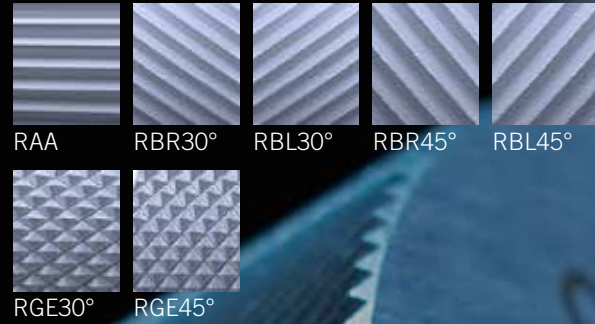

FORM KNURLING

With form knurling the surface of the workpiece is formed chipless. Cold forming is used to shape the material, which limits its use to materials that are suitable for cold forming.





ADDED VALUES

- machining of the workpiece by cold forming, which compresses the surface of the workpiece
- knurling is possible up to a workpiece shoulder
- all knurling profiles according to DIN 82 can be produced
- knurling is possible at any position on the workpiece
- knurling of inner and end faces is possible
- conical knurling is possible

OVERVIEW OF FORM KNURLING TOOLS

With the product finder for form knurling tools you can find your desired QUICK product faster. You receive all relevant tool data, as well as possible profiles, the corresponding knurling wheels and the possible direction of machining at a glance.



Tool series	Workpiece Ø [mm]	Profile on workpiece	Profile on knurling wheel	Shank [mm]	Knurling wheel Ø [mm]	Knurling	RAA	RBL	RBR	RGE
NEW  F701 PAGE 18	2.5 – 30 10 – 50 8 – 200	RAA RBR30° RBL30° RBR45° RBL45°	AA BL30° BR30° BL45° BR45°	10 / 12 / 16 20 / 25	10 / 15 20 / 25	Workpiece centre / without plunge cut (radial) Starting at workpiece beginning Starting in centre of workpiece / after plunge cut Starting in centre of workpiece / without plunge cut Up to a shoulder Starting at workpiece beginning up to the collar	● ● ● ● – –	● ● ● ● – –	● ● ● ● – –	– – – – – –
 F711 PAGE 19	2.5 – 24 7 – 120	RAA RBR30° RBL30° RBR45° RBL45° RGE30° RGE45°	2 x AA 2 x BL30° 2 x BR30° 2 x BL45° 2 x BR45° 1 x BR30° + 1 x BL30° 1 x BR45° + 1 x BL45°	10 / 12 / 16 20 / 25	10 20	Workpiece centre / without plunge cut (radial) Starting at workpiece beginning Starting in centre of workpiece / after plunge cut Starting in centre of workpiece / without plunge cut Up to a shoulder Starting at workpiece beginning up to the collar	● ● ● ● ● – –	● ● ● ● ● – –	● ● ● ● ● – –	● ● ● ● ● – –
NEW  F712 PAGE 20	3.5 – 50 7 – 120	RAA RBR30° RBL30° RBR45° RBL45° RGE30° RGE45°	2 x AA 2 x BL30° 2 x BR30° 2 x BL45° 2 x BR45° 1 x BR30° + 1 x BL30° 1 x BR45° + 1 x BL45°	8 / 10 / 12 20 / 25	9.8 20	Workpiece centre / without plunge cut (radial) Starting at workpiece beginning Starting in centre of workpiece / after plunge cut Starting in centre of workpiece / without plunge cut Up to a shoulder Starting at workpiece beginning up to the collar	● ● ● ● ● ● ●	● ● ● ● ● ● ●	● ● ● ● ● ● ●	● ● ● ● ● ● ●
 F751 PAGE 21	5 – 20* 0 – 15	RAA RBR30° RBL30° RBR45° RBL45° RGE30° RGE45°	2 x AA 2 x BL30° 2 x BR30° 2 x BL45° 2 x BR45° 1 x BR30° + 1 x BL30° 1 x BR45° + 1 x BL45°	 12	10 15	Workpiece centre / without plunge cut (radial) Starting at workpiece beginning Starting in centre of workpiece / after plunge cut Starting in centre of workpiece / without plunge cut Up to a shoulder Starting at workpiece beginning up to the collar	● ● ● ● ● – –	● ● ● ● ● – –	● ● ● ● ● – –	● ● ● ● ● – –
NEW  F761 PAGE 22	10 – 45	RAA RBR30° RBL30° RBR45° RBL45° RGE30° RGE45°	2 x AA 2 x BL30° 2 x BR30° 2 x BL45° 2 x BR45° 1 x BR30° + 1 x BL30° 1 x BR45° + 1 x BL45°	 20 / 25	 20 / 25	Workpiece centre / without plunge cut (radial) Starting at workpiece beginning Starting in centre of workpiece / after plunge cut Starting in centre of workpiece / without plunge cut Up to a shoulder Starting at workpiece beginning up to the collar	● ● ● ● ● – –	● ● ● ● ● – –	● ● ● ● ● – –	● ● ● ● ● – –

*possibly parameter adjustment is necessary on the machine



NEW

FORM KNURLING TOOL F701



KNURLING PROFILE ON WORKPIECE (DIN 82):

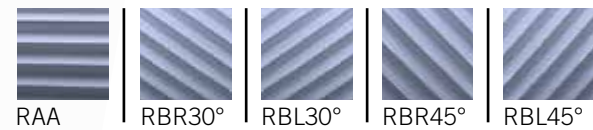

SELECTION OF KNURLING WHEELS (DIN 403):

AA | BL30° | BR30° | BL45° | BR45°

PRODUCT FEATURES

- small, stable and compact for fast, single-wheel use
- firmly defined center height
- adjustment of the axis parallelism possible

Item no. (right-hand version)	Item no. (left-hand version)	Model	Workpiece Ø [mm]	Knurling wheel (Ø x w x b) [mm]	Dimensions [mm]							
					a	b	c	d	e	f	x	
32000398 <input checked="" type="checkbox"/>	32000406	F701-10	2.5/10-30/50	10/15 x 4 x 4	10	10	101	12	21	18.5	1.5/4	
32000402 <input checked="" type="checkbox"/>	32000407	F701-12	2.5/10-30/50	10/15 x 4 x 4	12	12	101	12	21	19.5	1.5/4	
32000403 <input checked="" type="checkbox"/>	32000408	F701-16	2.5/10-30/50	10/15 x 4 x 4	16	16	101	16	21	23.5	1.5/4	

Available from factory stock

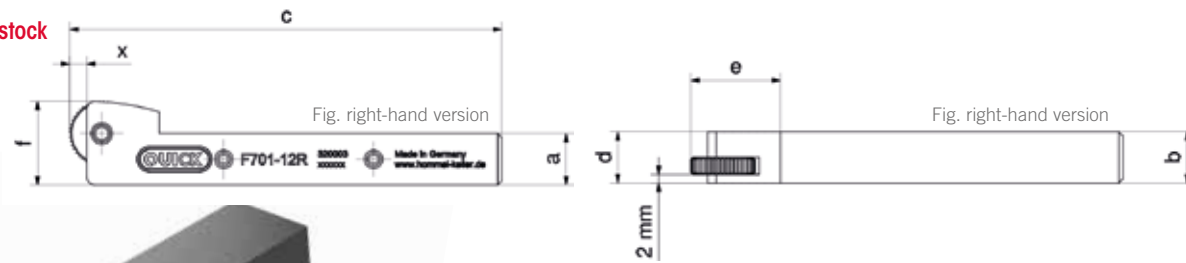

KNURLING PROFILE ON WORKPIECE (DIN 82):

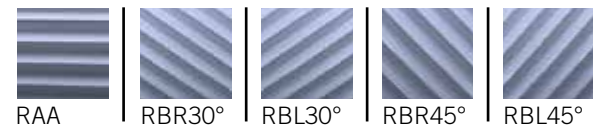

SELECTION OF KNURLING WHEELS (DIN 403):

AA | BL30° | BR30° | BL45° | BR45°

PRODUCT FEATURES

- stable and compact for fast, single-wheel use
- firmly defined center height
- adjustment of the axis parallelism possible

Item no.	Model	Workpiece Ø [mm]	Knurling wheel (Ø x w x b) [mm]	Dimensions [mm]							
				a	b	c	d	e	f	x	
32000399 <input checked="" type="checkbox"/>	F701-20U	8 - 200	20/25 x 8 x 6	20	20	107.5	20	27.5	32.5	3/5.5	
32000404 <input checked="" type="checkbox"/>	F701-25U	8 - 200	20/25 x 8 x 6	25	20	107.5	20	27.5	37.5	3/5.5	

Available from factory stock

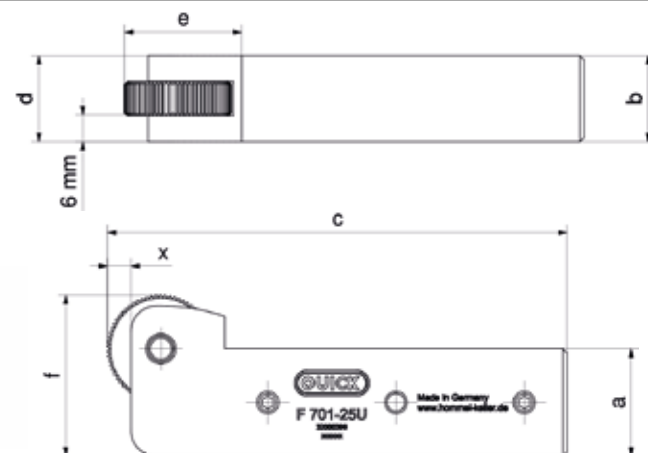

SPARE PARTS F701

PIN F701

Item no.	Knurling wheel (Ø x w x b) [mm]	Shank dimensions [mm]
06TER1015	10/15 x 4 x 4	10 x 12 / 12 x 12
06TER1036	10/15 x 4 x 4	16 x 16
06TER1018	20/25 x 8 x 6	20 x 20 / 25 x 20



FORM KNURLING TOOL F711



KNURLING PROFILE ON WORKPIECE (DIN 82):



SELECTION OF KNURLING WHEELS (DIN 403):

2x AA | 2x BL30° | 2x BR30° | 2x BL45° | 2x BR45° | 1x BR30° | 1x BR45° | 1x BL30° | 1x BL45°

PRODUCT FEATURES

- all common knurl profiles can be produced
- firmly defined center height
- adjustment of the axis parallelism possible

Item no. (right-hand version)	Item no. (left-hand version)	Model	Workpiece Ø [mm]	Knurling wheel (Ø x w x b) [mm]	Dimensions [mm]							
					a	b	c	d	e	f	x	
32000226 <input checked="" type="checkbox"/>	32000353	F711-10	2.5 - 24	10 x 4 x 4	10	10	101.5	16.5	21.5	24	2	
32000223 <input checked="" type="checkbox"/>	32000368	F711-12	2.5 - 24	10 x 4 x 4	12	12	101.5	16.5	21.5	24	2	
32000367 <input checked="" type="checkbox"/>	32000369	F711-16	2.5 - 24	10 x 4 x 4	16	16	101.5	16.5	21.5	24	2	

Available from factory stock

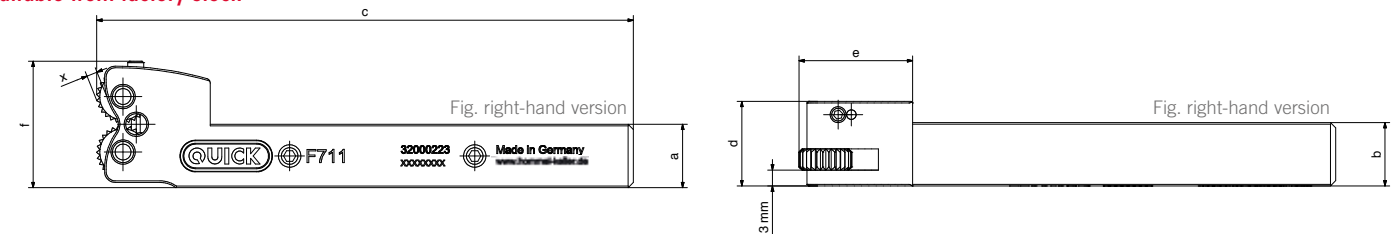

PRODUCT FEATURES

- all common knurl profiles can be produced
- firmly defined center height
- adjustment of the axis parallelism possible

Item no.	Model	Workpiece Ø [mm]	Knurling wheel (Ø x w x b) [mm]	Dimensions [mm]							
				a	b	c	d	e	f	x	
32000217 <input checked="" type="checkbox"/>	F711-20U	7 - 120	20 x 8 x 6	20	20	104.5	20	24.5	40.4	2.5	
32000218 <input checked="" type="checkbox"/>	F711-25U	7 - 120	20 x 8 x 6	25	20	104.5	20	24.5	45.2	2.5	

Available from factory stock

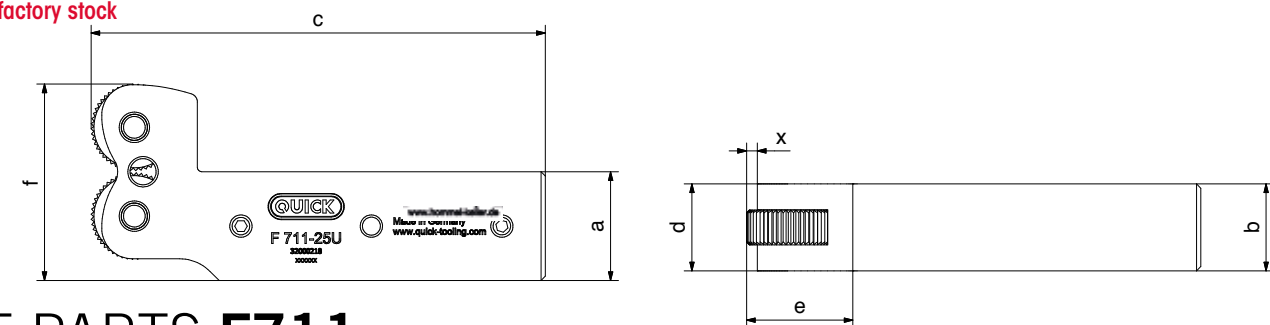

SPARE PARTS F711

PIN F711

Item no.	Knurling wheel (Ø x w x b) [mm]
06TER1036	10 x 4 x 4
06TER0965	20 x 8 x 6



FORM KNURLING TOOL F712

NEW



KNURLING PROFILE ON WORKPIECE (DIN 82):



SELECTION OF KNURLING WHEELS (DIN 403):

2x AA	2x BL30°	2x BR30°	2x BL45°	2x BR45°	1x BR30° 1x BL30°	1x BR45° 1x BL45°
-------	----------	----------	----------	----------	----------------------	----------------------

PRODUCT FEATURES

- optimized for Swiss type lathe applications
- very small and compact design
- all common knurl profiles can be produced
- knurling up to a shoulder
- firmly defined center height
- adjustment of the axis parallelism possible

Item no.	Model	Workpiece Ø [mm]	Knurling wheel (Ø x w x b) [mm]	Dimensions [mm]							
				a	b	c	d	e	f	x	
32000375 <input checked="" type="checkbox"/>	F712-08U-LD	3 - 45	9,8 x 3,5 x 6A7,5	8	8	115.7	13	15.7	19.8	1	
32000419 <input checked="" type="checkbox"/>	F712-10U-LD	3 - 45	9,8 x 3,5 x 6A7,5	10	10	115.7	13	15.7	19.8	1	
32000420 <input checked="" type="checkbox"/>	F712-12U-LD	3 - 45	9,8 x 3,5 x 6A7,5	12	12	115.7	13	15.7	19.8	1	

Available from factory stock

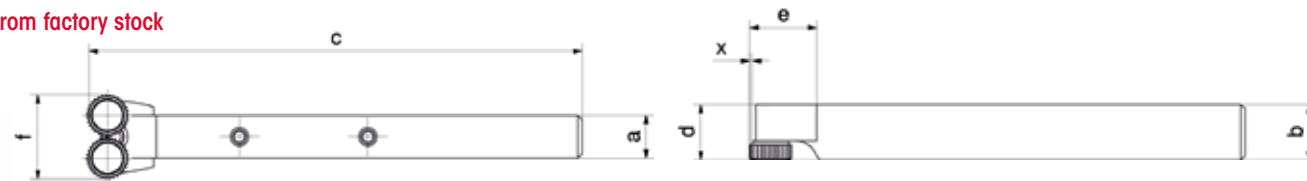

KNURLING PROFILE ON WORKPIECE (DIN 82):



SELECTION OF KNURLING WHEELS (DIN 403):

2x AA	2x BL30°	2x BR30°	2x BL45°	2x BR45°	1x BR30° 1x BL30°	1x BR45° 1x BL45°
-------	----------	----------	----------	----------	----------------------	----------------------

PRODUCT FEATURES

- knurling up to a shoulder
- all common knurl profiles can be produced
- firmly defined center height
- adjustment of the axis parallelism possible

Item no. (right-hand version)	Item no. (left-hand version)	Model	Workpiece Ø [mm]	Knurling wheel (Ø x w x b) [mm]	Dimensions [mm]							
a	b	c	d	e	f	x						
32000219 <input checked="" type="checkbox"/>	32000229	F712-10	3.5 - 50	15 x 6 x 6A11	10	16	104.5	24	23.7	30.6	1.5	
32000220 <input checked="" type="checkbox"/>	32000230	F712-12	3.5 - 50	15 x 6 x 6A11	12	16	104.5	24	23.7	30.6	1.5	
32000370 <input checked="" type="checkbox"/>	32000371	F712-16	3.5 - 50	15 x 6 x 6A11	16	16	104.5	24	23.7	30.6	1.5	
32000209 <input checked="" type="checkbox"/>		F712-20U	7 - 120	20 x 8 x 6A13	20	20	104.5	26.5	24.5	40.4	2.5	
32000210 <input checked="" type="checkbox"/>		F712-25U	7 - 120	20 x 8 x 6A13	25	20	104.5	26.5	24.5	45.2	2.5	

Available from factory stock

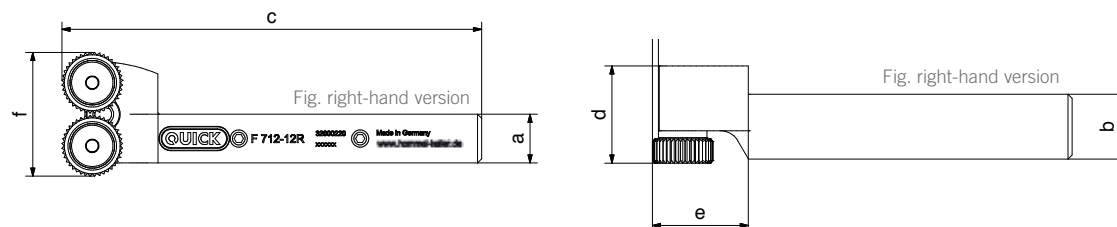

SPARE PARTS F712

E-KIT F712

Item no.	Knurling wheel (Ø x w x b) [mm]
22BHR2126	9.8 x 3.5 x 6A7.5
22BHR0548	15 x 6 x 6A11
22BHR0538	20 x 8 x 6A13



FORM KNURLING TOOL F751



KNURLING PROFILE ON WORKPIECE (DIN 82):



SELECTION OF KNURLING WHEELS (DIN 403):

2x AA	2x BL30°	2x BR30°	2x BL45°	2x BR45°	1x BR30° 1x BL30°	1x BR45° 1x BL45°
-------	----------	----------	----------	----------	----------------------	----------------------

PRODUCT FEATURES

- high process stability due to tangential machining
- optimized for Swiss type lathe applications
- eliminates double workplace allocation in the slide unit
- user-friendly handling

Item no. (right-hand version)	Model	Workpiece Ø [mm]	Knurling wheel (Ø x w x b) [mm]	Dimensions [mm]							
a	b	c	d	e	f	x					
32000211 <input checked="" type="checkbox"/>	F751-12	5 - 20	10 x 4 x 4	12	20	max. 122	21	max. 47	26	1	
		0 - 15	15 x 4 x 4							3.5	

Available from factory stock

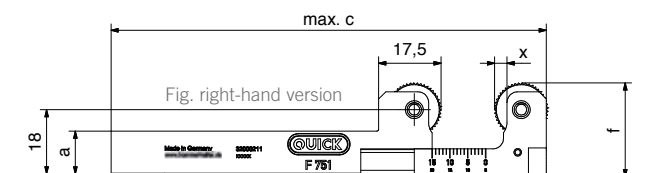

SPARE PARTS F751

PIN F751

Item no.	Knurling wheel (Ø x w x b) [mm]
06TER0964	10 / 15 x 4 x 4

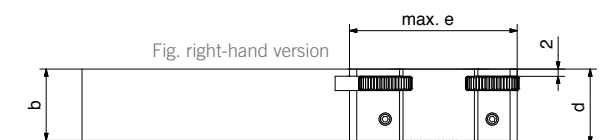

FORM KNURLING TOOL F761

NEW



KNURLING PROFILE ON WORKPIECE (DIN 82):

SELECTION OF KNURLING WHEELS (DIN 403):

2x AA	2x BL30°	2x BR30°	2x BL45°	2x BR45°	1x BR30° 1x BL30°	1x BR45° 1x BL45°
-------	----------	----------	----------	----------	----------------------	----------------------

PRODUCT FEATURES

- high process stability to tangential machining
- knurl carrier can be adjusted separately
- force neutralisation due to tangential machining
- easy compensation of out-of-roundness due to special interface
- extension of the working area by exchange of jaws and knurling wheels
- quick and easy adjustment of the working area with the enclosed setting gauge

Item no.	Model	Workpiece Ø [mm]	Knurling wheel (Ø x w x b) [mm]	Dimensions [mm]						
				a	b	c	d	e	f	x
32000354 <input checked="" type="checkbox"/>	F761-20M	0 – 23	15 x 4 x 4	20	25	148.5	30	68.5	50	1.5
32000411 <input checked="" type="checkbox"/>		23 – 44	20 x 6 x 6			162		82	62	3
32000413 <input checked="" type="checkbox"/>	F761-25M	0 – 23	15 x 4 x 4	25	25	148.5	30	68.5	50	1.5
32000412 <input checked="" type="checkbox"/>		23 – 44	20 x 6 x 6			162		82	62	3

Available from factory stock

SPARE PARTS F761

PIN F761

Item no.	Knurling wheel (Ø x w x b) [mm]
21BHR1306	15 x 4 x 4
21BHR1459	20 x 6 x 6

JAWS F761

Item no.	Knurling wheel (Ø x w x b) [mm]
22BHR0740	15 x 4 x 4
22BHR0739	20 x 6 x 6

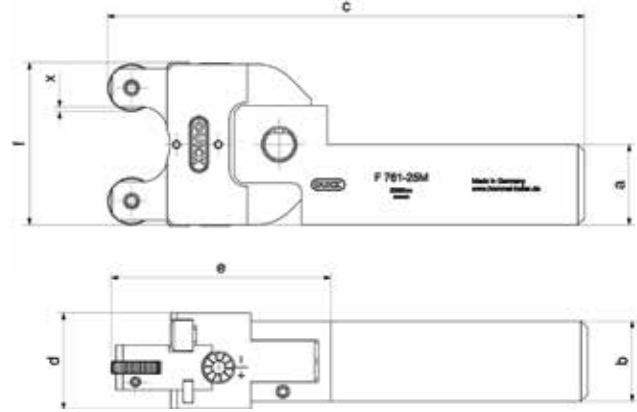

APPLICATION EXAMPLE FORM KNURLING

F701 | F711 TWO PROFILES ON ONE WORKPIECE WITHIN ONE MACHINING PROCESS



PROFILE RBR45°
PROFILE RBL45°

F701 | USE OF TWO TOOLS
KNURLING WHEELS: 1x BL45° | 1x BR45°

F711 | ADJUSTMENT VIA THE Y-AXIS
KNURLING WHEELS: 1x BL45° | 1x BR45°

F711 | F761 PROFILE RGE



PROFILE RGE30°

F711 | VERY HIGH PROCESS STABILITY
KNURLING WHEELS: 1x BL30° | 1x BR30°

F761 | OPTIMAL FORCE NEUTRALISATION - PERFECT FOR LONG AND THIN-WALLED WORKPIECES
KNURLING WHEELS: 1x BL30° | 1x BR30°

F701 | F712 PROFILE RAA



PROFILE RAA

F701 | USER-FRIENDLY HANDLING, VERY HIGH PROCESS STABILITY
KNURLING WHEEL: 1x AA

F712 | PROFILE UP TO A SHOULDER
KNURLING WHEELS: 2x AA

ONE TOOL FOR FORM KNURLING AND CUT KNURLING

KNURLING TOOL WITH

KNURLING TOOL
WITH CUT JAWS:
C693



KNURLING PROFILE ON WORKPIECE (DIN 82) WITH C693:



RAA | RGE30° | RGE45°

SELECTION OF KNURLING WHEELS (DIN 403):

1x BR30° | 3x AA | 2x BR15°
2x BL30° | 1x BL15°

INTERCHANGEABLE JAWS



KNURLING TOOL
WITH FORM JAWS
F791



KNURLING TOOL
WITH FORM JAWS
F792



KNURLING PROFILE ON WORKPIECE (DIN 82) WITH F791 AND F792:

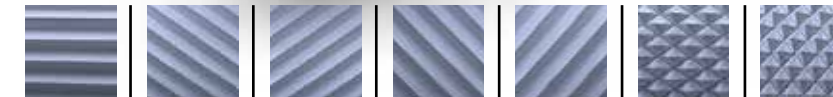

RAA | RBR30° | RBL30° | RBR45° | RBL45° | RGE30° | RGE45°

SELECTION OF KNURLING WHEELS (DIN 403):

3x AA | 3x BL30° | 3x BR30° | 3x BL45° | 3x BR45° | 1x BR30° | 2x BL30° | 1x BR45° | 2x BL45°
2x BR30° | 1x BL30° | 2x BR45° | 1x BL45° or

PRODUCT FEATURES

- knurl holders individually adjustable
- maximum process stability
- all knurling processes can be used by exchanging the jaws
- suitable for very small installation spaces due to compact design
- force reduction through three-point machining

PRODUCT FEATURES F792

- knurling up to a shoulder

Item no.	Model	Workpiece Ø [mm]	Knurling wheel (Ø x w x b) [mm]	Dimensions [mm]						
				d _{max}	e	j	k	l	n _{max}	x
32000030 <input checked="" type="checkbox"/>	C693	3.5 – 20	14.5 x 3 x 5	75	57	20	54	20	38	1.7
32000029 <input checked="" type="checkbox"/>		5.5 – 35	21.5 x 5 x 8	125	92	35	95	40	69	1.7
32000072 <input checked="" type="checkbox"/>	F791	2.6 – 20	10 x 4 x 4	75	53	20	54	16	32	1
		3.5 – 20	15 x 4 x 4							3.5
32000206 <input checked="" type="checkbox"/>	F792	3.5 – 20	15 x 6 x 6A11	75	54	20	54	17	41	1.5

Tool is delivered without shank.

Available from factory stock

SPARE PARTS

SHANKS C693 (14.5x3x5) / F791 / F792

Item no.	Ø „a“ [mm]	Bore „i“ [mm]	Length „h“ [mm]
22BHR0119	15	9	50
22BHR0121	20	10	50
22BHR0644	22	14	50
22BHR0122	25	15	50

SHANKS C693 (21.5x5x8)

Item no.	Ø „a“ [mm]	Bore „i“ [mm]	Length „h“ [mm]
22BHR0103	20	10	70
22BHR0104	25	15	70

INTERCHANGEABLE JAWS

Item no.	Description	Tool
22BHR0536	cut knurling	C693
22BHR0490	form knurling	F791
22BHR0537	form knurling up to a shoulder	F792

E-KIT

Item no. C693	Item no. F792	Knurling wheel (Ø x w x b) [mm]
22BHR0507	–	14.5 x 3 x 5
22BHR0508	–	21.5 x 5 x 8
–	22BHR0548	15 x 6 x 6A11

PIN

Item no.
F791
21BHR1306

DIMENSIONS C693

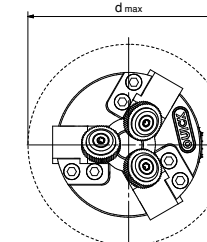
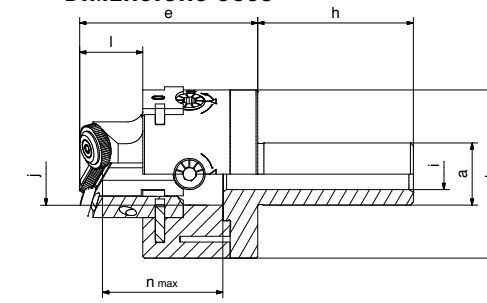

DIMENSIONS F791

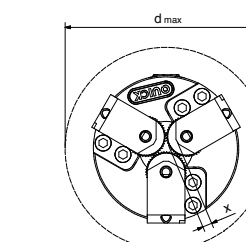
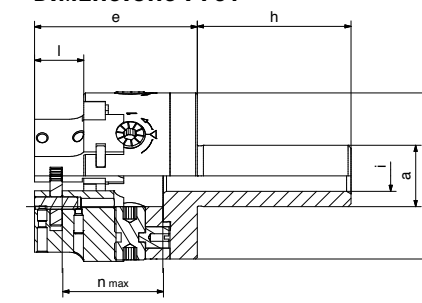

DIMENSIONS F792

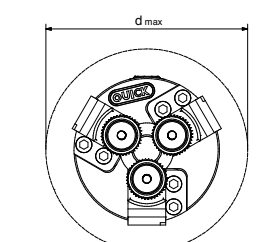
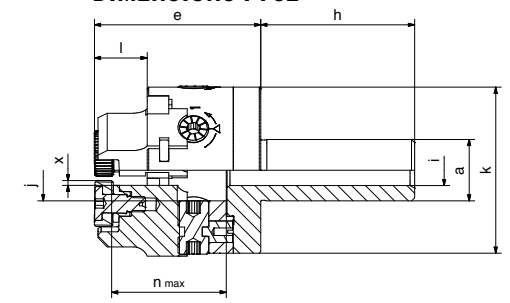

KNURLING WHEELS

The QUICK knurling wheels listed here are available from factory stock.

Of course QUICK knurling wheels with special dimensions and special pitches are available on request.

OVERVIEW KNURLING



QUICK knurling wheels according to DIN 403 for profiles according to DIN 82, no chamfer, PM

Profile AA

Item no.	Product group	Profile	Angle	Ø (mm)	Width (mm)	Bore (mm)	Pitch (mm)
42000182	135	AA	0	8.9	2.5	4	0.3
42000183	135	AA	0	8.9	2.5	4	0.4
42000184	135	AA	0	8.9	2.5	4	0.5
42000185	135	AA	0	8.9	2.5	4	0.6
42000186	135	AA	0	8.9	2.5	4	0.8
42000187	135	AA	0	8.9	2.5	4	1.0
42000216	135	AA	0	14.5	3	5	0.3
42000217	135	AA	0	14.5	3	5	0.4
42000218	135	AA	0	14.5	3	5	0.5
42000219	135	AA	0	14.5	3	5	0.6
42000220	135	AA	0	14.5	3	5	0.8
42000221	135	AA	0	14.5	3	5	1.0
42000222	135	AA	0	14.5	3	5	1.2
42000262	135	AA	0	21.5	5	8	0.5
42000263	135	AA	0	21.5	5	8	0.6
42000264	135	AA	0	21.5	5	8	0.8
42000265	135	AA	0	21.5	5	8	1.0
42000266	135	AA	0	21.5	5	8	1.2
42000267	135	AA	0	21.5	5	8	1.5
42000268	135	AA	0	21.5	5	8	1.6
42000269	135	AA	0	21.5	5	8	2.0
42000282	135	AA	0	32	8	14	1.5
42000283	135	AA	0	32	8	14	2.0
42010562	135	AA	0	32	8	14	2.5
42000285	135	AA	0	32	8	14	3.0
42000314	135	AA	0	42	12	18	1.5
42000315	135	AA	0	42	12	18	2.0
42000316	135	AA	0	42	12	18	2.5
42000317	135	AA	0	42	12	18	3.0

WHEELS CUTTING



Profile BL

Item no.	Product group	Profile	Angle	Ø (mm)	Width (mm)	Bore (mm)	Pitch (mm)
42000159	135	BL	15	8.9	2.5	4	0.4
42000160	135	BL	15	8.9	2.5	4	0.5
42000161	135	BL	15	8.9	2.5	4	0.6
42000162	135	BL	15	8.9	2.5	4	0.8
42000163	135	BL	15	8.9	2.5	4	1.0
42000170	135	BL	30	8.9	2.5	4	0.3
42000171	135	BL	30	8.9	2.5	4	0.4
42000172	135	BL	30	8.9	2.5	4	0.5
42000173	135	BL	30	8.9	2.5	4	0.6
42000174	135	BL	30	8.9	2.5	4	0.8
42000175	135	BL	30	8.9	2.5	4	1.0
42000190	135	BL	15	14.5	3	5	0.5
42000191	135	BL	15	14.5	3	5	0.6
42000192	135	BL	15	14.5	3	5	0.8
42000193	135	BL	15	14.5	3	5	1.0
42000194	135	BL	15	14.5	3	5	1.2
42000203	135	BL	30	14.5	3	5	0.4
42000204	135	BL	30	14.5	3	5	0.5
42000205	135	BL	30	14.5	3	5	0.6
42000206	135	BL	30	14.5	3	5	0.8
42000207	135	BL	30	14.5	3	5	1.0
42000208	135	BL	30	14.5	3	5	1.2
42000224	135	BL	15	21.5	5	8	0.5
42000225	135	BL	15	21.5	5	8	0.6
42000226	135	BL	15	21.5	5	8	0.8
42000227	135	BL	15	21.5	5	8	1.0
42000228	135	BL	15	21.5	5	8	1.2
42000229	135	BL	15	21.5	5	8	1.5
42000230	135	BL	15	21.5	5	8	1.6
42000231	135	BL	15	21.5	5	8	2.0
42000244	135	BL	30	21.5	5	8	0.5
42000245	135	BL	30	21.5	5	8	0.6
42000246	135	BL	30	21.5	5	8	0.8
42000247	135	BL	30	21.5	5	8	1.0
42000248	135	BL	30	21.5	5	8	1.2
42000249	135	BL	30	21.5	5	8	1.5
42000250	135	BL	30	21.5	5	8	1.6
42000251	135	BL	30	21.5	5	8	2.0
42000272	135	BL	15	32	8	14	1.5
42000273	135	BL	15	32	8	14	2.0
42000274	135	BL	15	32	8	14	2.5
42000275	135	BL	15	32	8	14	3.0
42000293	135	BL	15	42	12	18	1.5
42000294	135	BL	15	42	12	18	2.0
42000295	135	BL	15	42	12	18	2.5
42000296	135	BL	15	42	12	18	3.0
42000805	135	BL	30	42	12	18	1.5
42000806	135	BL	30	42	12	18	2.0
42000304	135	BL	30	42	12	18	3.0

Profile BR

Item no.	Product group	Profile	Angle	Ø (mm)	Width (mm)	Bore (mm)	Pitch (mm)
42000165	135	BR	15	8.9	2.5	4	0.4
42000166	135	BR	15	8.9	2.5	4	0.5
42000167	135	BR	15	8.9	2.5	4	0.6
42000168	135	BR	15	8.9	2.5	4	0.8
42000169	135	BR	15	8.9	2.5	4	1.0
42000176	135	BR	30	8.9	2.5	4	0.3
42000177	135	BR	30	8.9	2.5	4	0.4
42000178	135	BR	30	8.9	2.5	4	0.5
42000179	135	BR	30	8.9	2.5	4	0.6
42000180	135	BR	30	8.9	2.5	4	0.8
42000181	135	BR	30	8.9	2.5	4	1.0
42000197	135	BR	15	14.5	3	5	0.5
42000198	135	BR	15	14.5	3	5	0.6
42000199	135	BR	15	14.5	3	5	0.8
42000200	135	BR	15	14.5	3	5	1.0
42000201	135	BR	15	14.5	3	5	1.2
42000210	135	BR	30	14.5	3	5	0.4
42000211	135	BR	30	14.5	3	5	0.5
42000212	135	BR	30	14.5	3	5	0.6
42000213	135	BR	30	14.5	3	5	0.8
42000214	135	BR	30	14.5	3	5	1.0
42000215	135	BR	30	14.5	3	5	1.2
42000234	135	BR	15	21.5	5	8	0.5
42000235	135	BR	15	21.5	5	8	0.6
42000236	135	BR	15	21.5	5	8	0.8
42000237	135	BR	15	21.5	5	8	1.0
42000238	135	BR	15	21.5	5	8	1.2
42000239	135	BR	15	21.5	5	8	1.5
42000240	135	BR	15	21.5	5	8	1.6
42000241	135	BR	15	21.5	5	8	2.0
42000253	135	BR	30	21.5	5	8	0.5
42000254	135	BR	30	21.5	5	8	0.6
42000255	135	BR	30	21.5	5	8	0.8
42000256	135	BR	30	21.5	5	8	1.0
42000257	135	BR	30	21.5	5	8	1.2
42000258	135	BR	30	21.5	5	8	1.5
42000259	135	BR	30	21.5	5	8	1.6
42000260	135	BR	30	21.5	5	8	2.0
42000277	135	BR	15	32	8	14	1.5
42000278	135	BR	15	32	8	14	2.0
42000279	135	BR	15	32	8	14	2.5
42000280	135	BR	15	32	8	14	3.0
42000299	135	BR	15	42	12	18	1.5
42000300	135	BR	15	42	12	18	2.0
42000301	135	BR	15	42	12	18	2.5
42000302	135	BR	15	42	12	18	3.0
42000307	135	BR	30	42	12	18	1.5
42000308	135	BR	30	42	12	18	2.0
42000310	135	BR	30	42	12	18	3.0



KNURLING WHEELS

The QUICK knurling wheels listed here are available from factory stock.

Of course QUICK knurling wheels with special dimensions and special pitches are available on request.

OVERVIEW KNURLING WHEELS FORMING



AA

QUICK knurling wheels according to DIN 403 for profiles according to DIN 82, with 45° chamfer, PM

Profile AA

Item no.	Product group	Profile	Angle	Ø (mm)	Width (mm)	Bore (mm)	Pitch (mm)
42010587	130	AA	0	9.8	3.5	6A7.5	0.5
42010588	130	AA	0	9.8	3.5	6A7.5	0.6
42010589	130	AA	0	9.8	3.5	6A7.5	0.8
42010590	130	AA	0	9.8	3.5	6A7.5	1.0
42000838	111	AA	0	10	4	4	0.3
42000839	111	AA	0	10	4	4	0.4
42000840	111	AA	0	10	4	4	0.5
42000841	111	AA	0	10	4	4	0.6
42001175	111	AA	0	10	4	4	0.7
42000842	111	AA	0	10	4	4	0.8
42000843	111	AA	0	10	4	4	1.0
42000859	111	AA	0	15	4	4	0.3
42000860	111	AA	0	15	4	4	0.4
42000861	111	AA	0	15	4	4	0.5
42000862	111	AA	0	15	4	4	0.6
42001191	111	AA	0	15	4	4	0.7
42000863	111	AA	0	15	4	4	0.8
42000864	111	AA	0	15	4	4	1.0
42000866	111	AA	0	15	4	4	1.2
42000975	111	AA	0	15	6	6A11	0.5
42001624	111	AA	0	15	6	6A11	0.6
42001786	111	AA	0	15	6	6A11	0.8
42001941	111	AA	0	15	6	6A11	1.0
42010551	111	AA	0	20	6	6	0.3
42010552	111	AA	0	20	6	6	0.4
42010553	111	AA	0	20	6	6	0.5
42010554	111	AA	0	20	6	6	0.6
42010555	111	AA	0	20	6	6	0.7
42010556	111	AA	0	20	6	6	0.8
42000708	111	AA	0	20	6	6	1.0
42000870	111	AA	0	20	6	6	1.2
42000871	111	AA	0	20	6	6	1.5
42010560	111	AA	0	20	6	6	1.6
42010561	111	AA	0	20	6	6	2.0
42001537	111	AA	0	20	8	6	0.3
42001542	111	AA	0	20	8	6	0.4
42000929	111	AA	0	20	8	6	0.5
42000930	111	AA	0	20	8	6	0.6
42000931	111	AA	0	20	8	6	0.8
42000943	111	AA	0	20	8	6	1.0
42000932	111	AA	0	20	8	6	1.2
42000933	111	AA	0	20	8	6	1.5
42001539	111	AA	0	20	8	6	1.6
42000883	111	AA	0	20	8	6	2.0

Profile AA

Item no.	Product group	Profile	Angle	Ø (mm)	Width (mm)	Bore (mm)	Pitch (mm)
42001510	111	AA	0	20	8	6A13	0,5
42001506	111	AA	0	20	8	6A13	0,6
42001507	111	AA	0	20	8	6A13	0,8
42000808	111	AA	0	20	8	6A13	1,0
42001508	111	AA	0	20	8	6A13	1,2
42001509	111	AA	0	20	8	6A13	1,5
42001161	111	AA	0	25	8	6	0,5
42001157	111	AA	0	25	8	6	0,6
42000832	111	AA	0	25	8	6	0,8
42000833	111	AA	0	25	8	6	1,0
42001158	111	AA	0	25	8	6	1,2
42001159	111	AA	0	25	8	6	1,5



OVERVIEW KNURLING WHEELS FORMING



BL30°



BL45°

QUICK knurling wheels according to DIN 403 for profiles according to DIN 82, with 45° chamfer, PM

Profile BL

Item no.	Product group	Profile	Angle	Ø (mm)	Width (mm)	Bore (mm)	Pitch (mm)
42010591	130	BL	30	9.8	3.5	6A7.5	0.5
42010592	130	BL	30	9.8	3.5	6A7.5	0.6
42010593	130	BL	30	9.8	3.5	6A7.5	0.8
42010594	130	BL	30	9.8	3.5	6A7.5	1.0
42010595	130	BL	45	9.8	3.5	6A7.5	0.5
42010596	130	BL	45	9.8	3.5	6A7.5	0.6
42010597	130	BL	45	9.8	3.5	6A7.5	0.8
42010598	130	BL	45	9.8	3.5	6A7.5	1.0
42002412	111	BL	30	10	4	4	0.3
42002413	111	BL	30	10	4	4	0.4
42002414	111	BL	30	10	4	4	0.5
42001129	111	BL	30	10	4	4	0.6
42001130	111	BL	30	10	4	4	0.8
42000817	111	BL	30	10	4	4	1.0
42001164	111	BL	45	10	4	4	0.5
42000846	111	BL	45	10	4	4	0.6
42000847	111	BL	45	10	4	4	0.8
42000848	111	BL	45	10	4	4	1.0
42001133	111	BL	30	15	4	4	0.5
42001134	111	BL	30	15	4	4	0.6
42001135	111	BL	30	15	4	4	0.8
42001136	111	BL	30	15	4	4	1.0
42009917	111	BL	30	15	6	6A11	0.5
42009824	111	BL	30	15	6	6A11	0.6
42001919	111	BL	30	15	6	6A11	0.8
42001799	111	BL	30	15	6	6A11	1.0
42009920	111	BL	45	15	6	6A11	0.5
42009795	111	BL	45	15	6	6A11	0.6
42002340	111	BL	45	15	6	6A11	0.8
42009742	111	BL	45	15	6	6A11	1.0

Profile BL

Item no.	Product group	Profile	Angle	Ø (mm)	Width (mm)	Bore (mm)	Pitch (mm)
42010563	111	BL	30	20	6	6	0.5
42010564	111	BL	30	20	6	6	0.6
42010565	111	BL	30	20	6	6	0.8
42010566	111	BL	30	20	6	6	1.0
42010567	111	BL	30	20	6	6	1.2
42010568	111	BL	30	20	6	6	1.5
42010569	111	BL	45	20	6	6	0.5
42010570	111	BL	45	20	6	6	0.6
42010571	111	BL	45	20	6	6	0.8
42010572	111	BL	45	20	6	6	1.0
42010573	111	BL	45	20	6	6	1.2
42010574	111	BL	45	20	6	6	1.5
42010575	111	BL	45	20	6	6	2.0
42001147	111	BL	30	20	8	6	0.5
42001148	111	BL	30	20	8	6	0.6
42001149	111	BL	30	20	8	6	0.8
42001150	111	BL	30	20	8	6	1.0
42001151	111	BL	30	20	8	6	1.2
42001514	111	BL	30	20	8	6	1.5
42001515	111	BL	30	20	8	6	1.6
42001517	111	BL	30	20	8	6	2.0
42000935	111	BL	45	20	8	6	0.6
42000936	111	BL	45	20	8	6	0.8
42000937	111	BL	45	20	8	6	1.0
42000944	111	BL	45	20	8	6	1.2
42000938	111	BL	45	20	8	6	1.5
42000885	111	BL	45	20	8	6	2.0
42010529	111	BL	30	20	8	6A13	0.8
42002326	111	BL	30	20	8	6A13	1.0
42001489	111	BL	30	20	8	6A13	1.2
42001497	111	BL	45	20	8	6A13	0.8
42001498	111	BL	45	20	8	6A13	1.0
42001499	111	BL	45	20	8	6A13	1.2



BR30°



BR45°

QUICK knurling wheels according to DIN 403 for profiles according to DIN 82, with 45° chamfer, PM

Profile BR

Item no.	Product group	Profile	Angle	Ø (mm)	Width (mm)	Bore (mm)	Pitch (mm)
42010599	130	BR	30	9.8	3.5	6A7.5	0.5
42010600	130	BR	30	9.8	3.5	6A7.5	0.6
42010601	130	BR	30	9.8	3.5	6A7.5	0.8
42010602	130	BR	30	9.8	3.5	6A7.5	1.0
42010603	130	BR	45	9.8	3.5	6A7.5	0.5
42010604	130	BR	45	9.8	3.5	6A7.5	0.6
42010605	130	BR	45	9.8	3.5	6A7.5	0.8
42010606	130	BR	45	9.8	3.5	6A7.5	1.0
42009921	111	BR	30	10	4	4	0.3
42009922	111	BR	30	10	4	4	0.4
42009923	111	BR	30	10	4	4	0.5
42001131	111	BR	30	10	4	4	0.6
42001132	111	BR	30	10	4	4	0.8
42000818	111	BR	30	10	4	4	1.0
42001170	111	BR	45	10	4	4	0.5
42001171	111	BR	45	10	4	4	0.6
42000856	111	BR	45	10	4	4	0.8
42000857	111	BR	45	10	4	4	1.0
42001138	111	BR	30	15	4	4	0.5
42001139	111	BR	30	15	4	4	0.6
42001140	111	BR	30	15	4	4	0.8
42001141	111	BR	30	15	4	4	1.0
42009926	111	BR	30	15	6	6A11	0.5
42009825	111	BR	30	15	6	6A11	0.6
42001920	111	BR	30	15	6	6A11	0.8
42009927	111	BR	30	15	6	6A11	1.0
42009930	111	BR	45	15	6	6A11	0.5
42009794	111	BR	45	15	6	6A11	0.6
42002339	111	BR	45	15	6	6A11	0.8
42009741	111	BR	45	15	6	6A11	1.0

Profile BR

Item no.	Product group	Profile	Angle	Ø (mm)	Width (mm)	Bore (mm)	Pitch (mm)
42010576	111	BR	30	20	6	6	0.5
42010577	111	BR	30	20	6	6	0.6
42010578	111	BR	30	20	6	6	0.8
42010579	111	BR	30	20	6	6	1.0
42010580	111	BR	30	20	6	6	1.2
42010581	111	BR	30	20	6	6	1.5
42001588	111	BR	45	20	6	6	0.5
42010582	111	BR	45	20	6	6	0.6
42010583	111	BR	45	20	6	6	0.8
42010584	111	BR	45	20	6	6	1.0
42010585	111	BR	45	20	6	6	1.2
42001406	111	BR	45	20	6	6	1.5
42010586	111	BR	45	20	6	6	2.0
42001152	111	BR	30	20	8	6	0.5
42001153	111	BR	30	20	8	6	0.6
42001154	111	BR	30	20	8	6	0.8
42001155	111	BR	30	20	8	6	1.0
42001156	111	BR	30	20	8	6	1.2
42001522	111	BR	30	20	8	6	1.5
42001523	111	BR	30	20	8	6	1.6
42001525	111	BR	30	20	8	6	2.0
42001533	111	BR	45	20	8	6	0.6
42000940	111	BR	45	20	8	6	0.8
42000941	111	BR	45	20	8	6	1.0
42000945	111	BR	45	20	8	6	1.2
42000942	111	BR	45	20	8	6	1.5
42000887	111	BR	45	20	8	6	2.0
42009957	111	BR	30	20	8	6A13	0.8
42001493	111	BR	30	20	8	6A13	1.0
42001494	111	BR	30	20	8	6A13	1.2
42001502	111	BR	45	20	8	6A13	0.8
42001503	111	BR	45	20	8	6A13	1.0
42001496	111	BR	45	20	8	6A13	1.2

QUICK MARKING TOOL

- Marking workpieces in seconds
- on a wide variety of geometries independent of the workpiece diameter
- changing marking text thanks to interchangeable marking segments
- for machines with small installation space
- marking up to a shoulder

MARKING TOOL



PRODUCT FEATURES

- modular shank design
- top edge of shank = centre height
- set screws in shank for correcting alignment
- hardened pin
- exact positioning of the marking on the circumference of the workpiece
- center height corresponds to the first marking point
- marking position individually adjustable

SPARE PARTS QBW 432

E-KIT - small version

Item no.	Direction	
22BHR0713	right	

E-KIT - big version

Item no.	Direction	
22BHR0714	right	

MARKING THE MOST DIFFERENT WORKPIECE GEOMETRIES

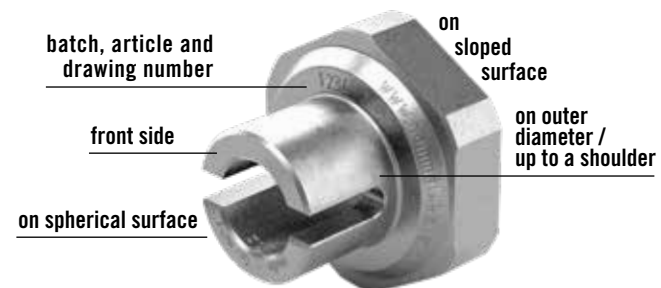

SET QBW 432

for QBW 432-30 - small version SET CONSISTING OF:

- 1 x base shank (solid shank version) tool 432-08R
- 1 x shank adapter 10 mm x 10 mm
- 1 x shank adapter 12 mm x 12 mm
- 1 x shank adapter 16 mm x 16 mm
- 1 x start and end segment
- in high-quality case

Available from factory stock

Item no.	Model	Dimensions [mm]						
		a	b	c	d	e	f	x
32000360	432-08R300818	8	8	113.5	31.5	33.5	30	1
	with shank adapter 10 x 10 mm	10	10	113.5	31.5	33.5	30	1
	with shank adapter 12 x 12 mm	12	12	113.5	31.5	33.5	30	1
	with shank adapter 16 x 16 mm	16	16	113.5	31.5	33.5	31	1

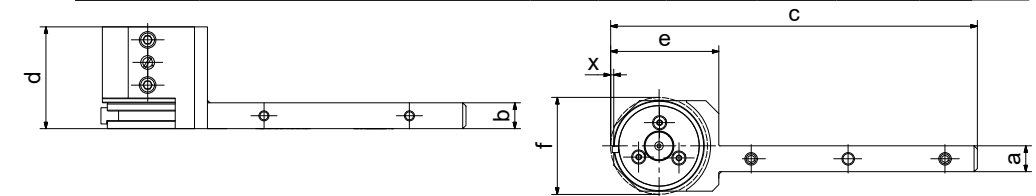

for QBW 432-50 - big version SET CONSISTING OF:

- 1 x base shank (solid shank version) tool 432-16R
- 1 x shank adapter 20 mm x 20 mm
- 1 x shank adapter 25 mm x 25 mm
- 1 x start and end segment
- in high-quality case

Available from factory stock

Item no.	Model	Dimensions [mm]						
		a	b	c	d	e	f	x
32000355	432-16R500838	16	16	138.5	31.5	58.5	50	1
	with shank adapter 20 x 20 mm	20	20	138.5	31.5	58.5	50	1
	with shank adapter 25 x 25 mm	25	25	138.5	31.5	58.5	50	1

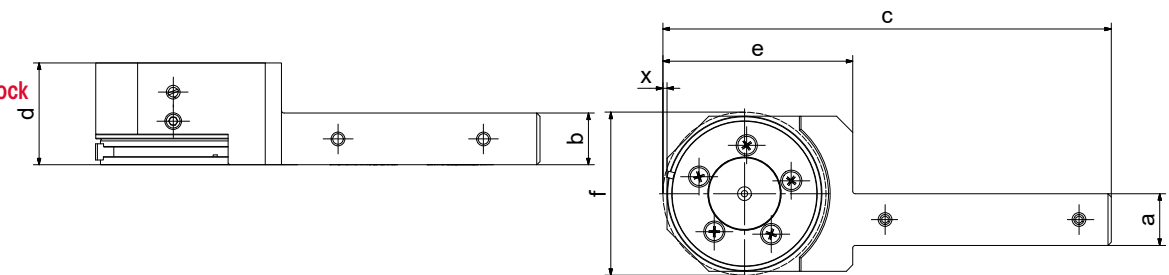

APPLICATION EXAMPLE MARKING

MARK YOUR WORKPIECE IN SECONDS.



INTEGRATED INTO THE MACHINING PROCESS

INTERCHANGEABLE MARKING TEXT
MARKING SEGMENTS IMMEDIATELY
AVAILABLE: A-Z, 0-9, -/.



MARKING SEGMENT N° 43



SEGMENT ø 30 - small version

Standard design	
flank angle	90°
dimension (ø x width x bore, mm)	30 x 8 x 18
font	according to DIN 1451



SEGMENT ø 50 - big version

Standard design	
flank angle	90°
dimension (ø x width x bore, mm)	50 x 8 x 38
font	according to DIN 1451

Item no. character height 2 mm	Item no. character height 3 mm	Segments designation
75000023		start segment
75000011	75000013	letter A-Z
75000059	75000060	A
75000063	75000089	B
75000064	75000090	C
75000065	75000091	D
75000066	75000092	E
75000067	75000093	F
75000068	75000094	G
75000069	75000095	H
75000070	75000096	I
75000071	75000097	J
75000072	75000098	K
75000073	75000099	L
75000074	75000100	M
75000075	75000101	N
75000076	75000102	O
75000077	75000103	P
75000078	75000104	Q
75000080	75000105	R
75000081	75000106	S
75000082	75000107	T
75000083	75000108	U
75000084	75000109	V
75000085	75000110	W
75000086	75000111	X
75000087	75000112	Y
75000088	75000113	Z
75000012	75000014	numeral set 0-9
75000164	75000174	0
75000165	75000175	1
75000166	75000176	2
75000167	75000177	3
75000168	75000178	4
75000169	75000179	5
75000170	75000180	6
75000171	75000181	7
75000172	75000182	8
75000173	75000183	9
75000040		space segment
75000015	75000016	special character - (Minus)
75000003	75000004	special character . (Dot)
75000005	75000006	special character / (Slash)
75000024		end segment

Item no. character height 2 mm	Item no. character height 3 mm	Segments designation
75000025		start segment
75000017	75000019	letter A-Z
75000061	75000062	A
75000114	75000139	B
75000115	75000140	C
75000116	75000141	D
75000117	75000142	E
75000118	75000143	F
75000119	75000144	G
75000120	75000145	H
75000121	75000146	I
75000122	75000147	J
75000123	75000148	K
75000124	75000149	L
75000125	75000150	M
75000126	75000151	N
75000127	75000152	O
75000128	75000153	P
75000129	75000154	Q
75000130	75000155	R
75000131	75000156	S
75000132	75000157	T
75000133	75000158	U
75000134	75000159	V
75000135	75000160	W
75000136	75000161	X
75000137	75000162	Y
75000138	75000163	Z
75000018	75000020	numeral set 0-9
75000184	75000194	0
75000185	75000195	1
75000186	75000196	2
75000187	75000197	3
75000188	75000198	4
75000189	75000199	5
75000190	75000200	6
75000191	75000201	7
75000192	75000202	8
75000193	75000203	9
75000039		space segment
75000021	75000022	special character - (Minus)
75000007	75000008	special character . (Dot)
75000009	75000010	special character / (Slash)
75000026		end segment

TECHNOLOGY KNURLING

CUTTING MACHINING

Cut knurling is a machining process that uses cutting.

Surface treatment - PVD coatings

For cut knurling processes we recommend different PVD coatings, since they can have a positive effect on the tool life of the knurling wheels. The following variants are available on request.

PVD coating	Colour sample	Suitable for
Q-Dur		Cold-work steel/hot-work steel/ high-speed steels/tempering steels (alternative)
Q-Blue		Stainless steels/high-speed steels/tempering steels/ titanium alloys
Q-Gold		Aluminium and brass alloys

NON-CUTTING MACHINING

Form knurling is a chipless machining process.

Surface treatment - TENIFER® salt-bath nitriding heat treatment

For form knurling processes we recommend the TENIFER® method, since the salt-bath nitrocarburising process achieves high surface hardness.

PROFILES AND PITCHES

DIN 403 describes and specifies the knurling profile on the knurling wheel. DIN 403 defines form knurling types AA, BL, BR und GE. Knurling wheels that deviate from DIN 403 are considered special knurling tools and are custom manufactured by Hommel+Keller based on customer drawings.

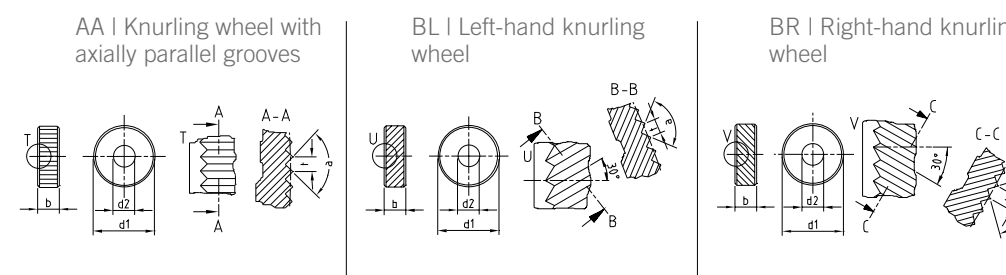

The knurling profile on the knurling wheel according to DIN 403 is based on the desired knurling profile on the workpiece (DIN 82) and the toolholder that is used. The knurling pitch prefers to the distance between tooth crests. The pitches = 0.5/0.6/0.8/1.0/1.2/1.6 are standard according to DIN 403. The Hommel+Keller product spectrum includes other pitches as well.

PROCESSING CHARACTERISTICS

CUT KNURLING

Knurling profiles on workpiece DIN 82

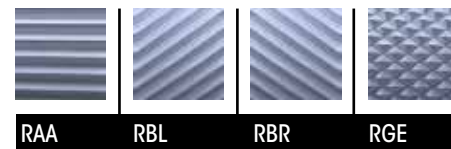

Application:

- cutting process
- material removal at axial feed drive
- machining of thin-walled, soft and hard-to-machine materials is possible
- only cylindrical workpieces can be machined in axial direction
- machining of small diameters is possible
- maximum precision and surface quality, therefore suitable primarily for visible knurling
- a plunge cut is necessary for applying the tool in the middle area of the workpiece
- knurling up to a shoulder is not possible

Handling:

- requires precise tool adjustment and fine adjustment
- requires precise preparation of the workpiece

Features:

- minimal change in the outer diameter
- minimal surface compaction
- lower strain on machine than in form knurling

FORM KNURLING

Knurling profiles on workpiece DIN 82

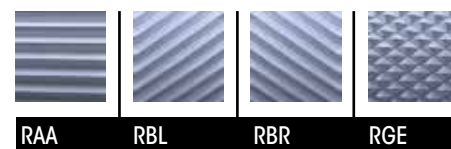

Application:

- non-cutting forming
- processing of workpieces suitable for cold forming
- all knurling forms and profiles can be manufactured
- suitable for face and knurling within a bore
- knurling up to a shoulder is possible
- tool can be started at any location on the workpiece

Handling:

- only minimal preparation of workpiece required
- very easy handling of tool (short setup times)

Features:

- material displacement increases the outer diameter of the workpiece
- the surface is compacted
- form knurling of small diameters is possible only to a limited extent

INFLUENCING FACTORS

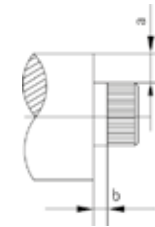

■ Clearance dimension for cut knurling – workpiece collar

Due to the design-related inclination (30°) of the knurling head and the overhang of the washer, knurling up to a collar is not possible with a cut knurling tool.

Dimension a corresponds to the increase in the step (mm). Dimension b corresponds to the minimum clearance for the respective knurling wheel (Ø specified in mm).

Dimension a is calculated with shoulder-height and 1/2 pitch with a flank angle of 90°.

a	b 8,9	b 14,5	b 21,5	b 32	b 42
1	1,0	1,3	2,0	1,5	1,8
2	2,5	1,8	2,6	2,5	3,0
3	3,0	2,2	3,0	3,1	4,3
4	3,0	2,6	3,8	3,8	5,7
5	3,0	2,8	4,5	4,5	6,7
6	3,0	3,1	4,7	5,1	7,5
7	3,0	3,1	5,0	6,2	8,1
8	3,0	3,1	5,3	7,6	8,6
9	3,0	3,1	5,3	9,4	9,1
10	3,0	3,1	5,3	9,8	9,5
11	3,0	3,1	5,3	10,4	9,8
12	3,0	3,1	5,3	10,6	10,1
13	3,0	3,1	5,3	10,8	12,2
14	3,0	3,1	5,3	11,1	13,1
15	3,0	3,1	5,3	11,1	13,6
16	3,0	3,1	5,3	11,1	14,1
17	3,0	3,1	5,3	11,1	14,4
18	3,0	3,1	5,3	11,1	14,6
19	3,0	3,1	5,3	11,1	14,8

Dimension a = shoulder-height + 1/2 pitch (flank angle 90°)

GUIDELINES FOR CUTTING SPEED & FEED RATE

Cut knurling process

Material	Workpiece Ø [mm]	Knurling wheel Ø [mm]	Vc [m/min]		f [mm/U]					
					Radial		Axial			
							Pitch [mm]			
					from	to	from	to	> 0.3 < 0.5	> 0.5 < 1.0
Free-cutting steel	< 10	8.9 / 14.5 / 21.5	40	70	0.04	0.08	0.20	0.13	0.08	0.07
	10 – 40	8.9 / 14.5 / 21.5 / 32 / 42	50	90	0.05	0.10	0.28	0.18	0.14	0.10
	40 – 100	14.5 / 21.5 / 32 / 42	65	110	0.05	0.10	0.35	0.25	0.17	0.11
	100 – 250	21.5 / 32 / 42	65	110	0.05	0.10	0.42	0.28	0.18	0.13
Stainless steel	< 10	8.9 / 14.5 / 21.5	22	40	0.04	0.08	0.14	0.09	0.06	0.05
	10 – 40	8.9 / 14.5 / 21.5 / 32 / 42	30	50	0.05	0.10	0.20	0.13	0.10	0.07
	40 – 100	14.5 / 21.5 / 32 / 42	35	60	0.05	0.10	0.25	0.18	0.12	0.08
	100 – 250	21.5 / 32 / 42	35	60	0.05	0.10	0.29	0.20	0.13	0.09
Brass	< 10	8.9 / 14.5 / 21.5	55	100	0.04	0.08	0.22	0.14	0.09	0.08
	10 – 40	8.9 / 14.5 / 21.5 / 32 / 42	70	125	0.05	0.10	0.31	0.20	0.15	0.11
	40 – 100	14.5 / 21.5 / 32 / 42	90	155	0.05	0.10	0.39	0.28	0.18	0.12
	100 – 250	21.5 / 32 / 42	90	155	0.05	0.10	0.46	0.31	0.20	0.14
Aluminium	< 10	8.9 / 14.5 / 21.5	70	120	0.04	0.08	0.12	0.08	0.05	0.04
	10 – 40	8.9 / 14.5 / 21.5 / 32 / 42	80	150	0.05	0.10	0.17	0.11	0.08	0.06
	40 – 100	14.5 / 21.5 / 32 / 42	110	160	0.05	0.10	0.21	0.15	0.10	0.07
	100 – 250	21.5 / 32 / 42	110	160	0.05	0.10	0.25	0.17	0.11	0.08

Form knurling process

Material	Workpiece Ø [mm]	Knurling wheel Ø [mm]	Vc [m/min]		f [mm/U]					
					Radial		Axial			
							Pitch [mm]			
					from	to	from	to	> 0.3 < 0.5	> 0.5 < 1.0
Free-cutting steel	< 10	10 / 15 / 20	20	50	0.04	0.08	0.14	0.09	0.06	0.05
	10 – 40	10 / 15 / 20 / 25	25	55	0.05	0.10	0.20	0.13	0.10	0.07
	40 – 100	15 / 20 / 25	30	60	0.05	0.10	0.25	0.18	0.12	0.08
	100 – 250	20 / 25	30	60	0.05	0.10	0.30	0.20	0.13	0.09
Stainless steel	< 10	10 / 15 / 20	15	40	0.04	0.08	0.12	0.08	0.05	0.04
	10 – 40	10 / 15 / 20 / 25	20	50	0.05	0.10	0.17	0.11	0.09	0.06
	40 – 100	15 / 20 / 25	25	50	0.05	0.10	0.21	0.15	0.10	0.07
Brass	< 10	10 / 15 / 20	30	75	0.04	0.08	0.15	0.09	0.06	0.05
	10 – 40	10 / 15 / 20 / 25	40	85	0.05	0.10	0.21	0.14	0.11	0.07
	40 – 100	15 / 20 / 25	45	90	0.05	0.10	0.26	0.19	0.13	0.08
Aluminium	< 10	10 / 15 / 20	25	60	0.04	0.08	0.18	0.11	0.08	0.06
	10 – 40	10 / 15 / 20 / 25	30	65	0.05	0.10	0.25	0.16	0.13	0.09
	40 – 100	15 / 20 / 25	35	70	0.05	0.10	0.31	0.23	0.15	0.10
	100 – 250	20 / 25	35	70	0.05	0.10	0.38	0.25	0.16	0.11

Important notice: This information represents reference values. The optimal values are to be found in the application. Ensure effective cooling/lubrication to prevent chips from being rolled into the profile and to prolong the life of the knurling wheels.



MATERIAL DISPLACEMENT IN FORM KNURLING PROCESS

Our empirical values for enlargement of the workpiece diameter

Knurling profile acc. to DIN 82: RAA (knurling profile on the workpiece)
Knurling wheels acc. to DIN 403: AA (knurling profile on knurling wheel)

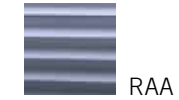

Material	Workpiece Ø [mm]	Pitch [mm]										
		0,3	0,4	0,5	0,6	0,7	0,8	1,0	1,2	1,5	1,6	2,0
		Enlargement of the workpiece diameter [mm]										
Free-cutting steel	5	0,08	0,14	0,18	0,22	0,27	0,29	0,35	0,50	–	–	–
	15	0,08	0,14	0,18	0,23	0,30	0,40	0,44	0,50	0,60	0,65	0,70
	25	0,08	0,15	0,23	0,24	0,28	0,35	0,44	0,53	0,62	0,70	0,98
Stainless steel	5	0,10	0,15	0,20	0,25	0,28	0,30	0,42	0,41	–	–	–
	15	0,10	0,15	0,19	0,25	0,30	0,34	0,45	0,51	0,60	–	–
	25	0,10	0,14	0,20	0,26	0,31	0,33	0,43	0,50	0,62	–	–
Brass	5	0,08	0,12	0,18	0,20	0,21	0,22	0,25	0,28	–	–	–
	15	0,10	0,14	0,20	0,26	0,28	0,29	0,35	0,41	0,44	0,48	0,55
Aluminium	5	0,09	0,15	0,19	0,23	0,28	0,30	0,41	0,40	–	–	–
	15	0,10	0,15	0,19	0,26	0,29	0,33	0,45	0,51	0,57	0,65	–
	25	0,09	0,15	0,19	0,26	0,29	0,32	0,45	0,52	0,59	0,65	0,75

Knurling profile acc. to DIN 82: RBR30°/ RBL30° (knurling profile on the workpiece)

Knurling wheels acc. to DIN 403: BR30°/ BL30° (knurling profile on knurling wheel)

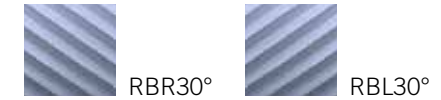

Material	Workpiece Ø [mm]	Pitch [mm]										
		0,3	0,4	0,5	0,6	0,7	0,8	1,0	1,2	1,5	1,6	2,0
		Enlargement of the workpiece diameter [mm]										
Free-cutting steel	5	0,11	0,15	0,20	0,24	0,28	0,34	0,45	0,55	–	–	–
	15	0,11	0,15	0,22	0,26	0,30	0,35	0,45	0,52	0,67	0,73	0,85
	25	0,11	0,14	0,23	0,25	0,28	0,36	0,45	0,56	0,70	0,72	0,90
Stainless steel	5	0,09	0,14	0,19	0,25	0,31	0,34	0,45	0,52	–	–	–
	15	0,12	0,20	0,23	0,31	0,35	0,40	0,51	0,62	0,66	0,73	0,97
	25	0,12	0,18	0,24	0,27	0,37	0,39	0,49	0,59	0,80	0,84	0,96
Brass	5	0,10	0,14	0,20	0,23	0,24	0,28	0,33	0,37	–	–	–
	15	0,10	0,15	0,21	0,23	0,24	0,31	0,41	0,47	0,53	0,55	0,63
Aluminium	5	0,12	0,14	0,21	0,24	0,29	0,34	0,41	0,51	–	–	–
	15	0,12	0,18	0,23	0,26	0,36	0,40	0,50	0,56	0,56	0,61	0,75
	25	0,12	0,18	0,25	0,28	0,37	0,39	0,50	0,58	0,77	0,82	0,96

Knurling profile acc. to DIN 82: RGE 30° (knurling profile on the workpiece)

Knurling wheels acc. to DIN 403: GE 30° (knurling profile on knurling wheel)



Material	Workpiece Ø [mm]	Pitch [mm]										
		0,3	0,4	0,5	0,6	0,7	0,8	1,0	1,2	1,5	1,6	2,0
		Enlargement of the workpiece diameter [mm]										
Free-cutting steel	5	0,12	0,16	0,20	0,25	0,33	0,41	0,55	0,65	–	–	–
	15	0,13	0,22	0,30	0,32	0,35	0,41	0,52	0,62	0,67	0,81	0,95
	25	0,12	0,18	0,28	0,32	0,35	0,38	0,55	0,67	0,77	0,87	0,98
Stainless steel	5	0,11	0,20	0,25	0,30	0,36	0,39	0,55	0,55	–	–	–
	15	0,10	0,14	0,21	0,24	0,29	0,34	0,43	0,53	0,66	0,72	0,88
	25	0,11	0,13	0,20	0,25	0,28	0,32	0,44	0,52	0,67	0,70	0,83
Brass	5	0,12	0,13	0,16	0,20	0,24	0,28	0,32	0,38	–	–	–
	15	0,12	0,16	0,18	0,24	0,28	0,30	0,39	0,40	0,48	0,52	0,63
	25	0,12	0,17	0,22	0,23	0,27	0,30	0,38	0,41	0,48	0,50	0,63
Aluminium	5	0,10	0,15	0,21	0,25	0,33	0,36	0,50	0,57	–	–	–
	15	0,11	0,14	0,20	0,25	0,28	0,33	0,43	0,54	0,67	0,71	0,89
	25	0,11	0,15	0,22	0,25	0,29	0,34	0,44	0,53	0,68	0,69	0,88

Important notice: This information represents empirical values. Deviations are possible.



**QUICK – is a brand
Hommel+Keller**



Platinum Tooling
16 E. Piper Lane, Suite 128
Prospect Heights, IL 60070
(847) 749-0633
info@platinumtooling.com
www.platinumtooling.com